

# Artemide®

## Tolomeo Faretto - Tolomeo Braccio

design  
M. De Lucchi  
G. Fassina

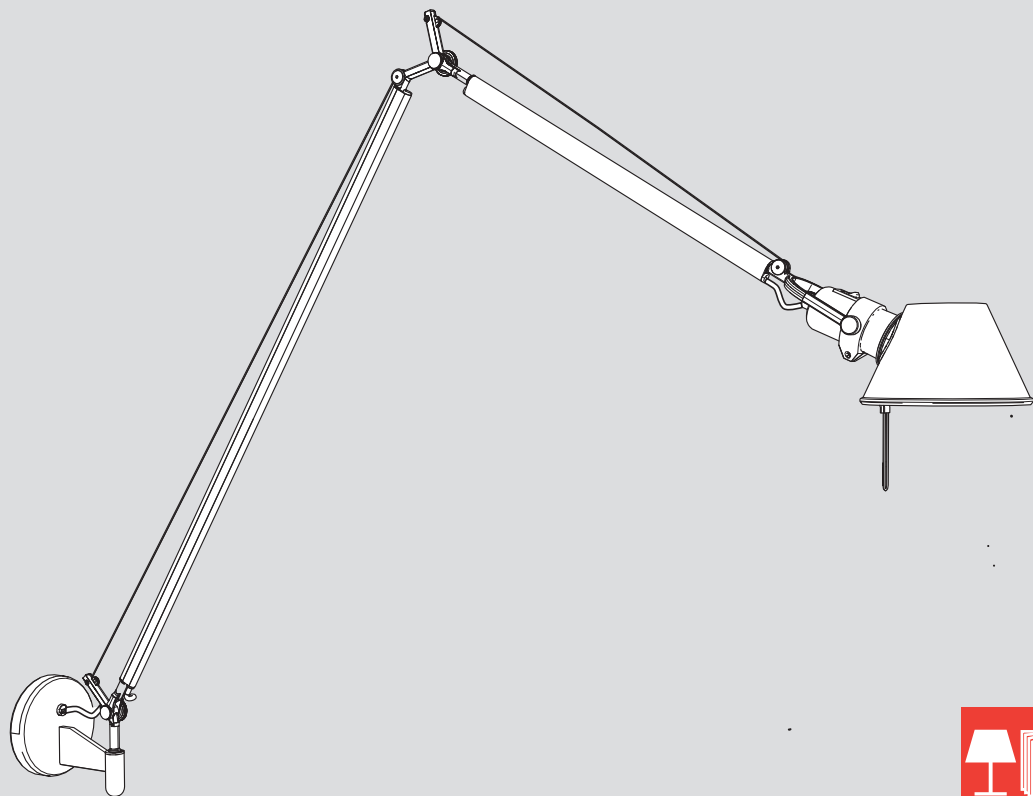

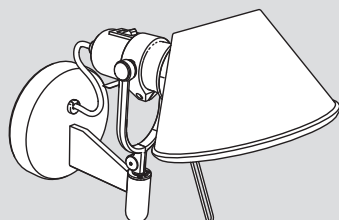
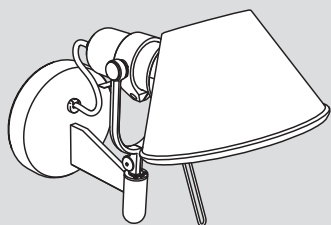

i

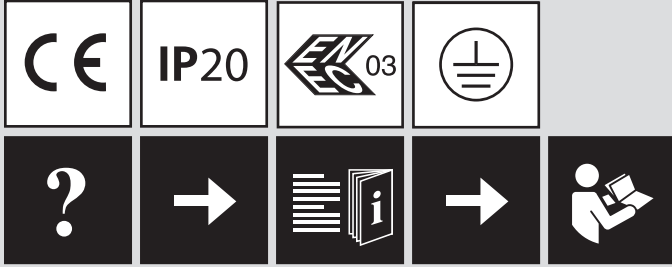

A025450  
A029250

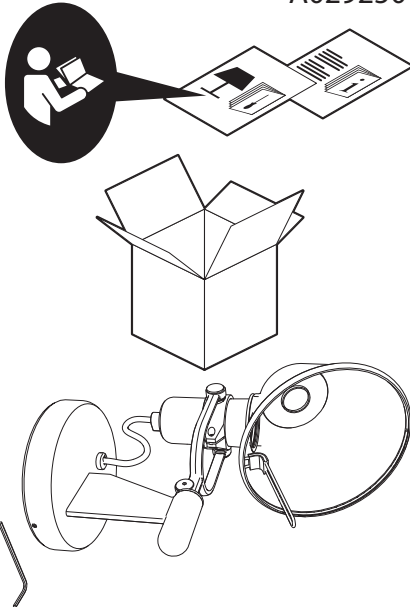

A029050

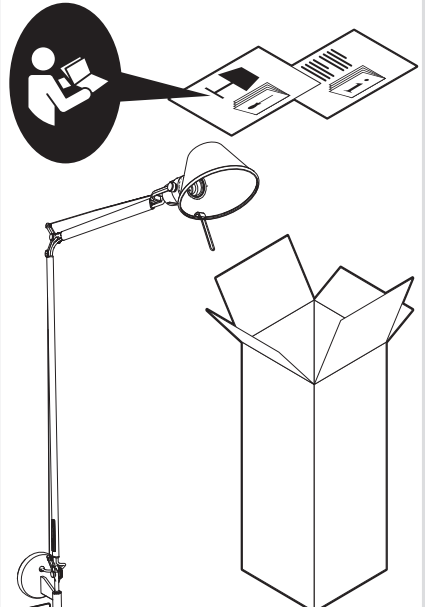

**1a**

A025450  
A029250

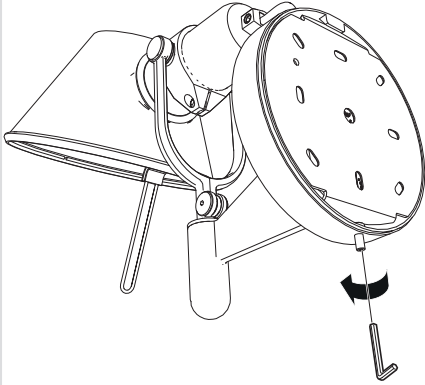

**1b**

A029050

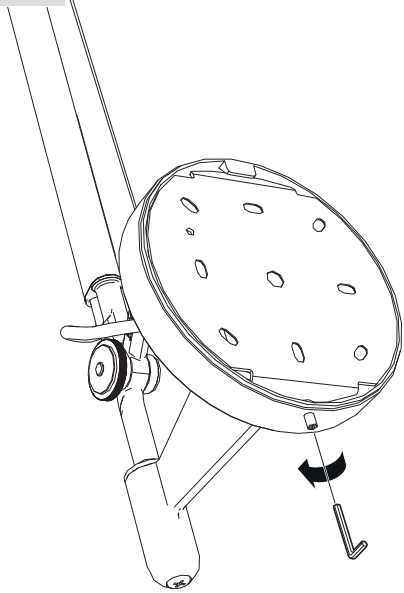

**2a**

A025450  
A029250

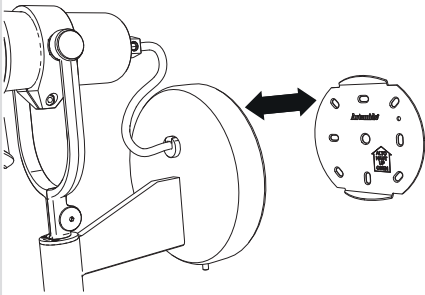

**2b**

A029050

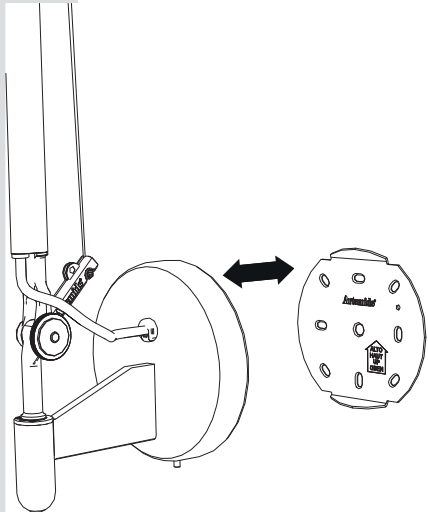

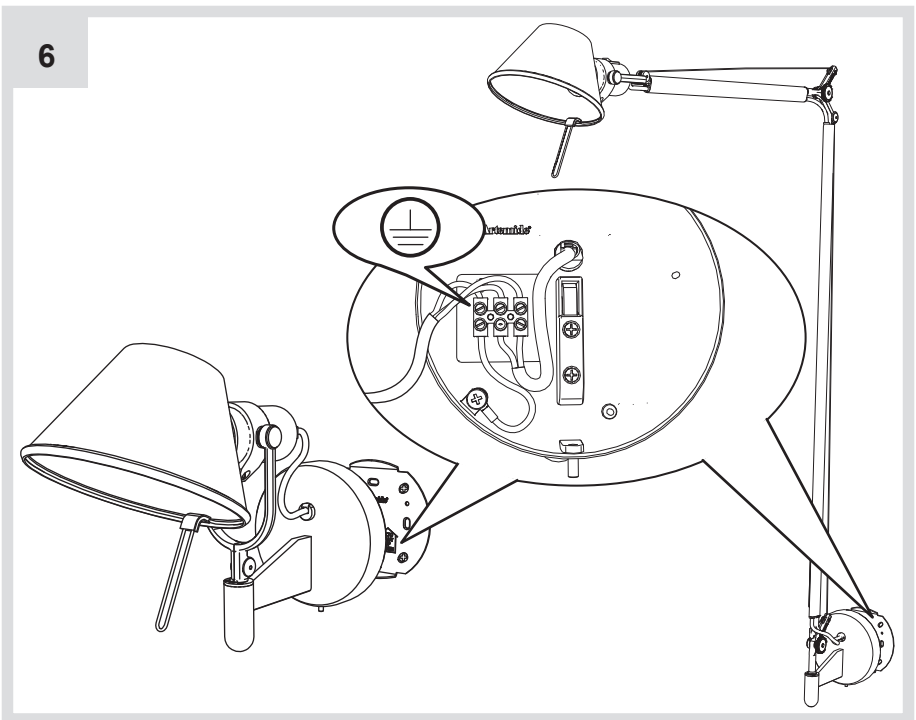
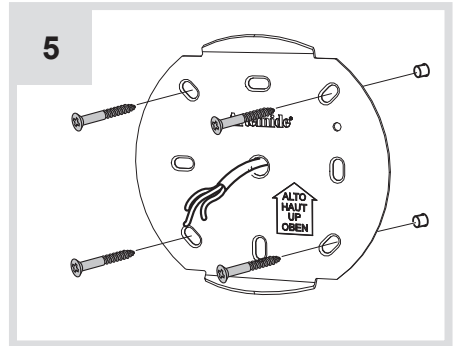
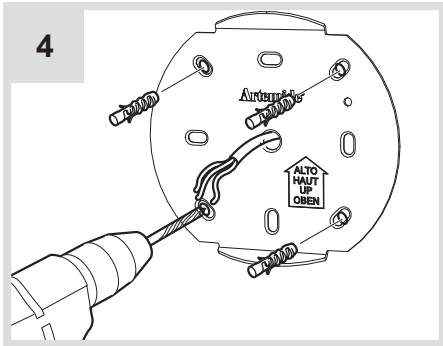
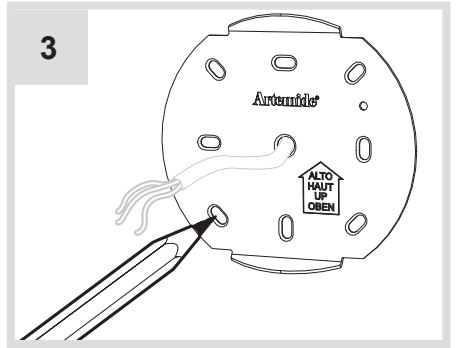
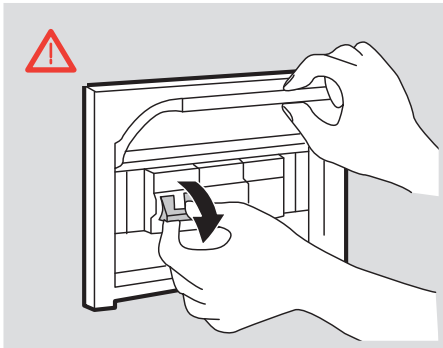

7a

A025450  
A029250

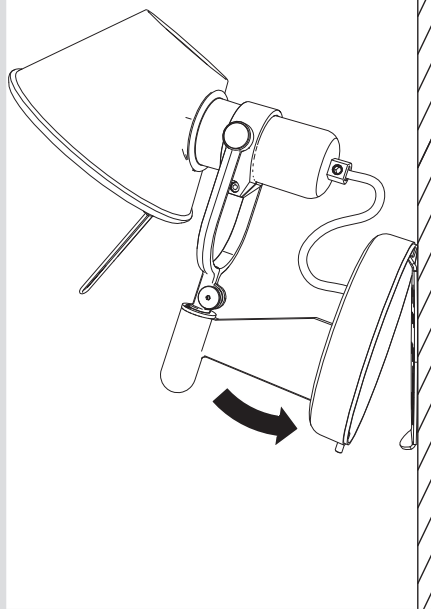

7b

A029050

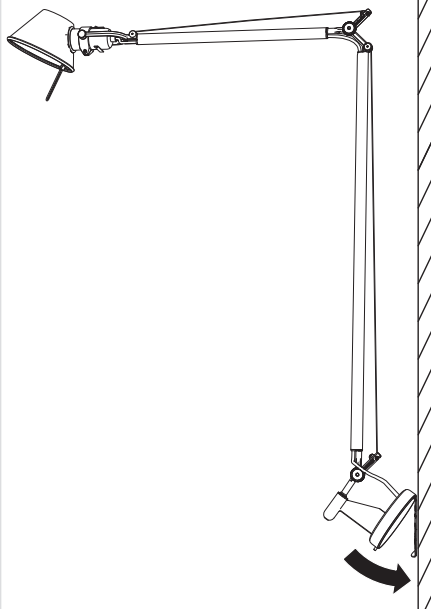

8a

A025450  
A029250

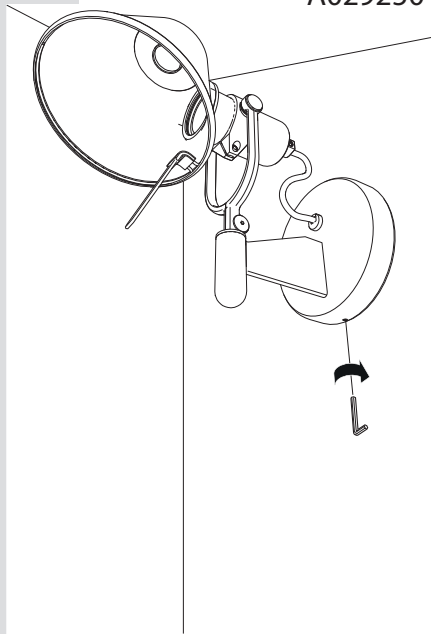

8b

A029050

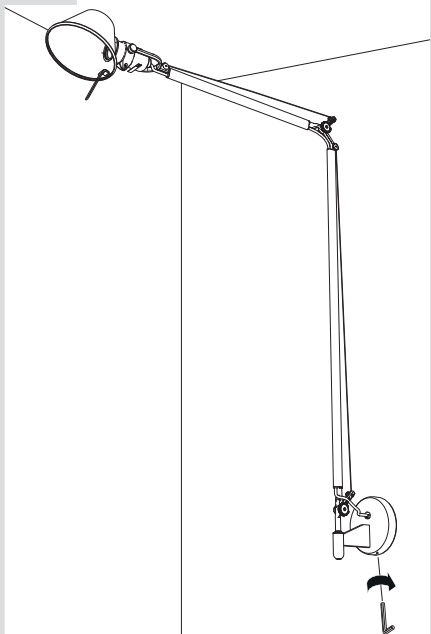

9a

A025450  
A029250

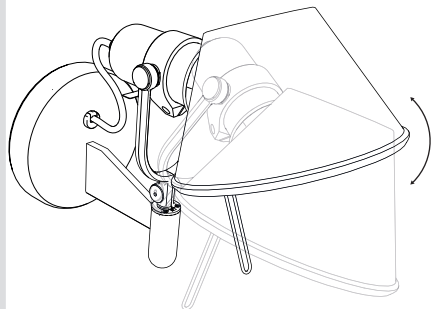

9b

A029050



A025450

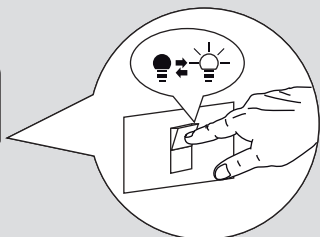
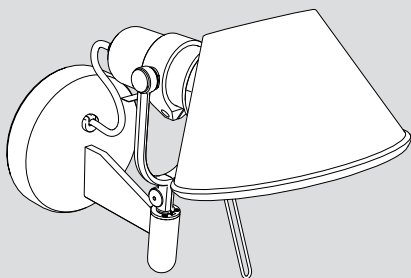

A029250  
A029050

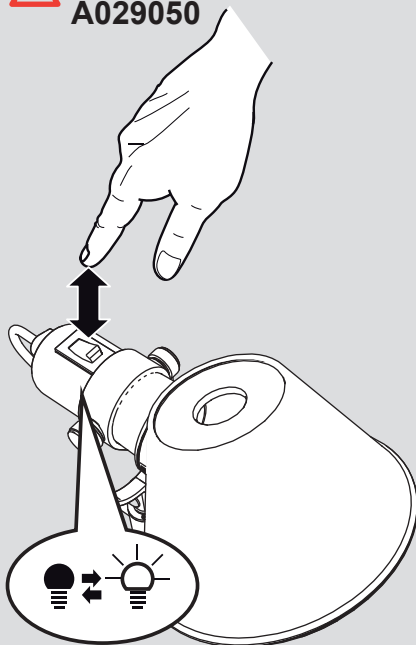



**i**

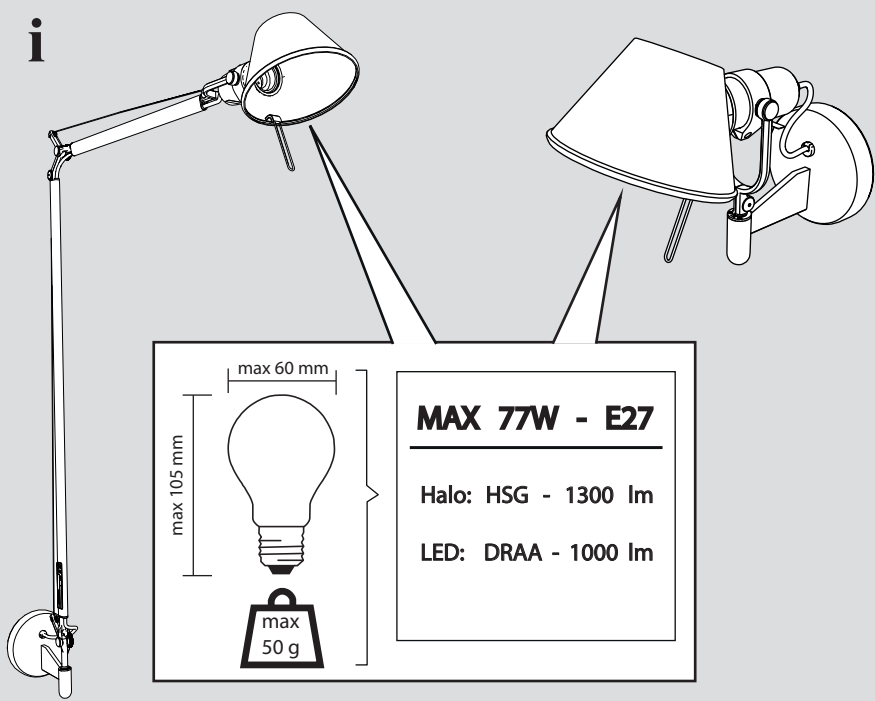

**i**

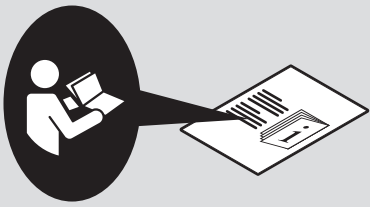

1

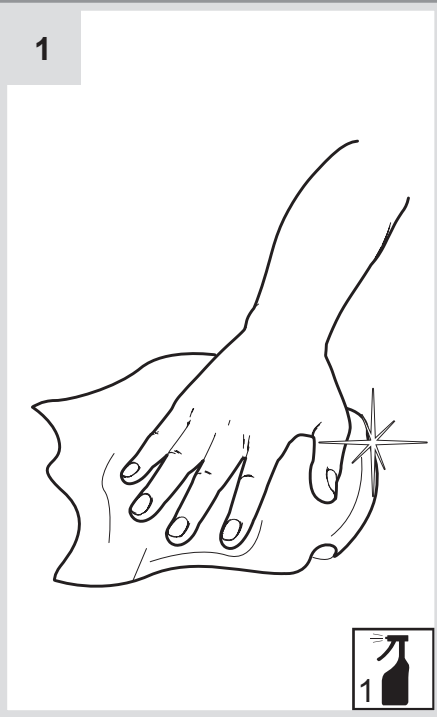

**Artemide®**



**Artemide**

via Bergamo, 18  
20010 Pregnana M.se (MI)  
ITALIA

tel. +39 02 935 181  
fax +39 02 935 90 254  
fax +39 02 935 90 496

[www.artemide.com](http://www.artemide.com)

VAT IT00846890150

cod. Y513000482



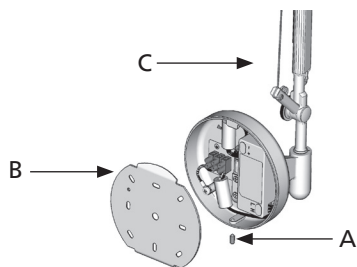

Fig. 1

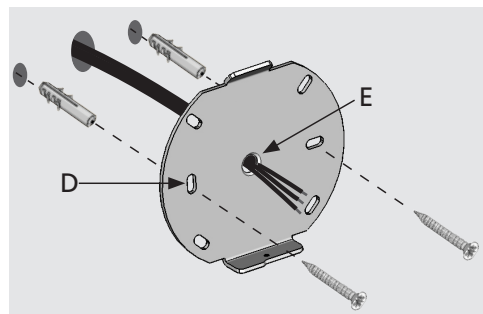

Fig. 2

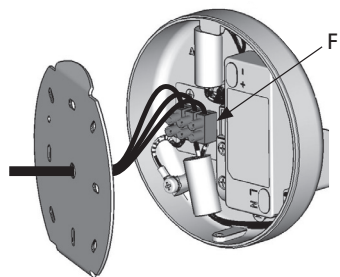

Fig. 3

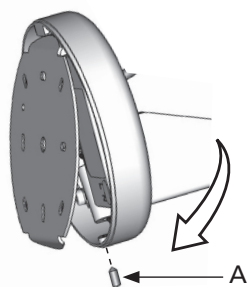

Fig. 4

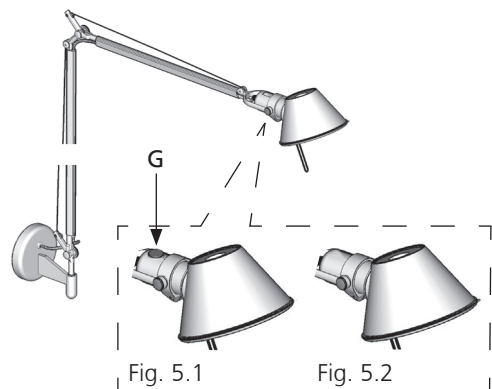

Fig. 5.1

Fig. 5.2

### AVVERTENZE

Prima di ogni operazione sull'apparecchio, disinserire la tensione di rete. L'apparecchio non può essere alimentato da presa comandata dimmerabile.

### AVIS

Déconnecter la tension de réseau avant toute opération sur l'appareil. L'appareil ne peut pas être alimenté par une prise commandée avec gradateur de lumière.

### WARNING

Before any operation on the fixture, disconnect the power supply. The fixture can not be supplied by an outlet provided with dimmer.

### VORSICHT

Vor jedem Eingriff an dem Gerät die Netzspannung unterbrechen. Das Gerät kann nicht durch eine gesteuerte Steckdose mit Dimmer versorgt werden.

### ADVERTENCIAS

Antes de efectuar cualquier operación, desconectar la tensión de red. El aparato no puede ser alimentado por una toma mandada con regulador de luz.

### INSTALLAZIONE

Allentare il grano A e sganciare la staffa B dal corpo C (Fig.1). Fissare la staffa al muro mediante le asole D. Fare passare i cavi dell'impianto elettrico attraverso il foro E (Fig. 2). Eseguire i collegamenti elettrici alla morsetteria F, collegando il cavo di messa a terra al polo contrassegnato con il simbolo  (fig. 3). Agganciare il corpo lampada C alla staffa B e serrare il grano A (Fig. 4). ATTENZIONE: allineare correttamente il corpo C con la staffa B!

**FUNZIONAMENTO VERS. DIMMERABILE:** L'apparecchio è dotato di un dimmer per la regolazione dell'intensità luminosa (Fig. 5.1). L'accensione avviene tramite un breve tocco dell'interruttore G. Tenere premuto l'interruttore per regolare l'intensità luminosa sino al livello desiderato o sino al livello massimo. Una seconda pressione prolungata dell'interruttore inverte il senso di regolazione dell'intensità luminosa verso il minimo. Spegnerlo l'apparecchio agendo sull'interruttore con un breve tocco. Alla riaccensione l'apparecchio riproduce la stessa intensità di luce impostata prima dello spegnimento.

**FUNZIONAMENTO VERS. ON/OFF:** Accensione/spegnimento tramite interruttore a parete (Fig. 5.2).

### INSTALLATION

Desserrer la vis sans tête A à l'aide de la clé Allen fournie et décrocher la bride B du corps C (Fig. 1). Fixer la bride au mur à l'aide des orifices D. Faire passer les câbles du système électrique à travers le trou E (Fig. 2). Exécuter les branchements électriques au bornier F, en reliant le câble de mise à la terre à la vis G marquée du symbole  (fig. 3). Accrocher le corps de la lampe C à la bride B et serrer la vis sans tête A (Fig. 4). ATTENTION : aligner correctement le corps C par rapport à la bride B !

**FONCTIONNEMENT DE LA VERS. RHÉOSTATÉE :** L'appareil est pourvu d'un rhéostat pour régler l'intensité lumineuse (Fig. 5.1). Pour l'allumer, toucher l'interrupteur H. Le maintenir enfoncé pour régler l'intensité lumineuse jusqu'au niveau voulu ou bien au niveau maximum. Une seconde pression prolongée de l'interrupteur inverse le sens de réglage de l'intensité lumineuse vers le niveau minimum. Toucher légèrement l'interrupteur pour éteindre l'appareil. Quand on rallume l'appareil, il reproduit l'intensité de lumière programmée avant son extinction.

**FONCTIONNEMENT VERS. ON/OFF:** Allumage/extinction à l'aide de l'interrupteur mural (Fig. 5.2).

### INSTALLATION

Loosen the grub screw using the Allen key included in the supply and remove the bracket B from the body C (Fig. 1). Mount the bracket on the wall, using the slots D. Route the electrical cables through the hole E (Fig. 2). Connect the wires to the terminal strip F, connect the ground wire to the screw G, marked with the  symbol (fig. 3). Insert the lamp body C into the bracket B and tighten the screw A (Fig. 4). ATTENTION: align the body C with the bracket B!

**DIMMABLE VERSION:** The device features a dimmer to adjust the light intensity (Fig. 5.1). Touch the switch H to switch on the device. Keep the switch pressed to adjust the light intensity, until the maximum or the preferred level has been reached. Press the switch again to reduce the light intensity. To switch off the device, touch the switch again. When the device is turned on again, the light intensity will be the one that was set up before turning off the device.

**ON/OFF VERSION:** Press the switch on the wall to switch on/off (Fig. 5.2).

### INSTALLATION

Den Stift A mit dem mitgelieferten Inbusschlüssel lösen und den Bügel B vom Körper C aushaken (Abb. 1). Den Bügel mithilfe der Ösen D an der Wand befestigen. Danach die Kabel der Elektroanlage durch die Bohrung E ziehen (Abb. 2). Die Stromkabel am Klemmbrett F und das Erdkabel an die Schraube G (mit dem Symbol  gekennzeichnet) anschließen (Abb. 3). Darauf den Lampenkörper C am Bügel B einhängen und den Stift A anziehen (Abb. 4). ACHTUNG: Den Körper C mit dem Bügel B korrekt ausrichten!

**BETRIEBSWEISE DER DIMMERBAREN AUSFÜHRUNG:** Das Gerät ist mit einem Dimmer zur Regelung der Lichtstärke ausgerüstet (Abb. 5.1). Die Einschaltung erfolgt durch eine kurze Berührung des Schalters H. Zur Regelung der Lichtstärke muss der Schalter gedrückt werden, bis die gewünschte oder maximale Lichtstärke erreicht wurde. Durch nochmaliges längeres Drücken des Schalters wird die Regelungsrichtung der Lichtstärke umgekehrt, d.h. reduziert. Durch eine kurze Berührung des Schalters kann das Gerät abgeschaltet werden. Beim Wiedereinschalten ist die Leuchte auf dieselbe Lichtstärke geregelt, wie vor dem Abschalten.

**BETRIEBSWEISE DER ON/OFF-AUSFÜHRUNG:** Ein-/Ausschaltung mit Wandschalter (Abb. 5.2).

### INSTALACIÓN

Aflojar el tornillo prisionero A con la llave Allen entregada y desenganchar el estribo B del cuerpo C (figura 1). Fijar el estribo a la pared a través de los ojales D. Hacer pasar los cables de la instalación eléctrica a través del orificio E (Figura 2). Ejecutar las conexiones eléctricas a la bornera F, conectando el cable de puesta a tierra al tornillo G marcado con el símbolo  (figura 3). Enganchar el cuerpo de la lámpara C en el estribo B y apretar el tornillo prisionero A (Figura 4). ATENCIÓN: ¡alinear correctamente el cuerpo C con el estribo B!

**FUNCIÓNAMIENTO DE LA VERSIÓN DIMMERIZABLE:** El equipo se ha equipado con un dimmer para la regulación de la intensidad luminosa (Figura 5.1). El encendido se realiza a través de un breve toque del interruptor H. Mantener apretado el interruptor para regular la intensidad luminosa hasta el nivel deseado y hasta el nivel máximo.

Una segunda presión prolongada del interruptor invierte el sentido de regulación de la intensidad luminosa hacia el mínimo. Apagar el equipo interviniendo en el interruptor con un breve toque. En el momento del reencendido el equipo reproduce la misma intensidad de luz configurada antes del apagado.

**FUNCIONAMIENTO DE LA VERSIÓN ON/OFF:** Encendido/apagado a través del interruptor de pared (Figura 5.2).

I

#### SOSTITUZIONE LED

All'apparecchio è abbinata una sorgente caratterizzata da una elevatissima vita utile. Tuttavia, nel caso fosse necessaria la sostituzione del led, questa dovrà essere effettuata esclusivamente da nostro personale specializzato. Siete pregati pertanto di rivolgervi al distributore più vicino. Per gli indirizzi dei distributori Artemide nel mondo, visitate il sito: [www.artemide.com](http://www.artemide.com).

F

#### REPLACEMENT LED

Une source avec une vie utile très longue est jointe à l'appareil. De toute façon, au cas où il serait nécessaire de remplacer le led, cette opération devra être effectuée exclusivement par notre personnel spécialisé. Vous êtes donc priés de vous adresser au distributeur le plus proche. Pour les adresses des distributeurs Artemide dans le monde, visiter le site: [www.artemide.com](http://www.artemide.com).

EN

#### LED REPLACEMENT

The fixture is provided with light source having a long life. Anyway, if the led must be replaced, this operation must be carried out only by our specialized staff. Therefore, we recommend contacting the nearest dealer. For the addresses of Artemide dealers in the world, visit our website: [www.artemide.com](http://www.artemide.com).

D

#### ERSATZ LED

Das Gerät ist mit einer Lichtquelle ausgerüstet, die eine lange Lebensdauer hat. Falls die LED ersetzt werden sollte, muss der Ersatz nur von unserem spezialisierten Personal ausgeführt werden. Es wird empfohlen den näher Verteiler zu kontaktieren. Für die Adressen der Verteiler Artemide in der Welt besuchen Sie unsere Internet-Site: [www.artemide.com](http://www.artemide.com).

ES

#### SUSTITUCIÓN LED

El aparato funciona con una fuente luminosa de muy larga duración. Sin embargo, una sustitución eventual del led debe ser efectuada exclusivamente por nuestro personal encargado. En este caso, por lo tanto, contacte con el distribuidor más cercano. Para encontrar las direcciones de los distribuidores de Artemide en el mundo, visite nuestro sitio: [www.artemide.com](http://www.artemide.com).

Avvertenze generali apparecchi di illuminazione per interni	Avertissements généraux pour appareils d'éclairage d'intérieur	General warnings for indoor light fittings	Generelle Hinweise für Beleuchtungsgeräte für Innenräume	Advertencias generales para aparatos de iluminación para interior
-------------------------------------------------------------	----------------------------------------------------------------	--------------------------------------------	----------------------------------------------------------	-------------------------------------------------------------------

Tutti i prodotti ARTEMIDE che rientrano nell'ambito di applicazione della direttiva europea bassa tensione B.T. 2006/95/CE e della direttiva europea compatibilità elettromagnetica E.M.C. 2004/108/CE soddisfano i requisiti richiesti e recano la marcatura "CE".

Tous les produits ARTEMIDE appartenant au champ d'application de la directive européenne basse tension B.T. 2006/95/CE et de la directive européenne compatibilité électromagnétique E.M.C. 2004/108/CE remplissent les conditions prévues et portent le marquage "CE".



All ARTEMIDE products falling within the range of application of the European low voltage directive B.T. 2006/95/EC and of the European electromagnetic compatibility E.M.C. directive 2004/108/EC meet the required specifications and bear "CE" labelling.

Alle Produkte von ARTEMIDE, die unter das Anwendungsgebiet der europäischen Richtlinie der Niederspannung B.T. 2006/95/EG und der elektromagnetischen Kompatibilität E.M.C. 2004/108/EG fallen, entsprechen den erforderlichen Eigenschaften und tragen das "CE" Kennzeichen.

Todos los productos ARTEMIDE que pertenecen al ámbito de aplicación de la directiva europea baja tensión B.T. 2006/95/CE y de la directiva europea compatibilidad electromagnética E.M.C. 2004/108/CE cumplen los requisitos correspondientes y llevan el marcado "CE".

L'apparecchio è stato testato secondo la norma IEC 62471:2006 sicurezza fotobiologica delle lampade – l'apparecchio ricade nel gruppo di rischio 1.

L'appareil a été testé selon la norme IEC 62471:2006 sécurité photobiologique des lampes – l'appareil fait partie dans le groupe de risque 1.

The fixture has been tested according to the standard IEC 62471:2006 photobiological safety of lamps – the fixture is classified in risk group 1.

Das Gerät wurde nach der Norm IEC 62471:2006 photobiologische Sicherheit von Lampen getestet – das Gerät ist in die Risikogruppe 1 eingeordnet.

El aparato ha sido ensayado según lo previsto por la norma IEC 62471:2006 seguridad fotobiológica de las lámparas – el aparato pertenece al grupo de riesgo 1.

ARTEMIDE s.p.a. non si assume alcuna responsabilità per prodotti modificati senza preventiva autorizzazione.

ARTEMIDE spa décline toute responsabilité pour les produits modifiés sans autorisation préalable.

ARTEMIDE spa does not shoulder any responsibilities for products which are modified without prior authorisation.

ARTEMIDE s.p.a. nimm keine Verantwortung für ohne Voreingehmigung geänderte Produkte an.

ARTEMIDE spa no se asume ninguna responsabilidad ante productos modificados sin autorización.

Nel caso si rendesse necessaria la sostituzione del cavo di alimentazione, contattare il centro assistenza tecnica ARTEMIDE.

Si le cordon d'alimentation doit être remplacé, contacter le service après vente ARTEMIDE.

For the replacement of the power supply cable, please apply to ARTEMIDE service centre.

Falls es nötig sein sollte das Speisekabel auszuwechseln, das technische Assistenzzentrum ARTEMIDE kontaktieren.

Si fuera necesario sustituir el cable de alimentación, póngase en contacto con el centro de asistencia técnica ARTEMIDE

Attenzione: la sicurezza elettrica di questo apparecchio è garantita con l'uso appropriato di queste istruzioni. Pertanto è necessario conservarle.

Attention: la sécurité de l'appareil n'est garantie que si les instructions sont convenablement suivies. Il est donc nécessaire de les conserver.

Warning: this equipment is guaranteed only when used as indicated in these instructions. Therefore they should be kept for future reference.

Achtung: die Sicherheit der Leuchte wird nur bei sachgerechtem Gebrauch gemäß Anweisungen gewährleistet. Bitte bewahren Sie diese sorgfältig auf.

Atencion: la seguridad del aparato está garantizada solo con el uso apropiado de las instrucciones. Por lo tanto es necesario conservarlas.

In caso di reclamo citare il numero

En cas de réclamation, veuillez citer le numéro

In case of complaint, please quote number

Bei jeder Reklamation geben Sie, bitte folgende Nummer an

En caso de reclamación indicar el número



cod. Y503001981

**Artemide**

via Bergamo, 18

20010 Pregnana M.se (MI) - ITALIA

tel. 02935261

fax 0293290362

Linea verde: 1678.24035

