

# GRAVITY

GRAVITY is the new magnetic system of FLEX collection. A versatile and distinctive galaxy of graphic elements capable of enhancing any environment and providing a focal lighting effect. Installed magnetically with a mechanical extra security feature. Offered for trimless, ceiling and pendant mounting, linear units use a 48V power supply and allow the integration of multiple solutions, installed through magnetic and mechanical fixing, meeting different interior needs. Adjustable spots emphasise any setting due to maximum flexibility and the anti-glare retracted lens for accent or diffuse lighting. Linear modules are proposed with an opal screen for homogeneous and welcoming lighting. For high visual comfort and optimal glare control over the entire surface, the system is completed by UGR<19 units: recessed or fold, respectively for direct or adjustable light emission. GRAVITY can be installed individually or in multiple configurations, creating geometric figures with 90° angles.



# TRACK CEILING | 1M

## LAMPING

Tension	48V
Dimensions	100x2,6x5,4
Materials	Aluminium
Notes	pendant version available
Customization options	recessed trim version
Accessories	Ceiling-Pendant Track 48V - accessories,   Ceiling-Trimless Track 48V - accessories,
Net lamp weight	0,97 kg

## Codes

MFLE0210NE

## Structure

black

## PACKAGE

Package 01

Dimension: 107x7,5x7,5 cm / Gross weight: 1,28 kg

## Certificazioni

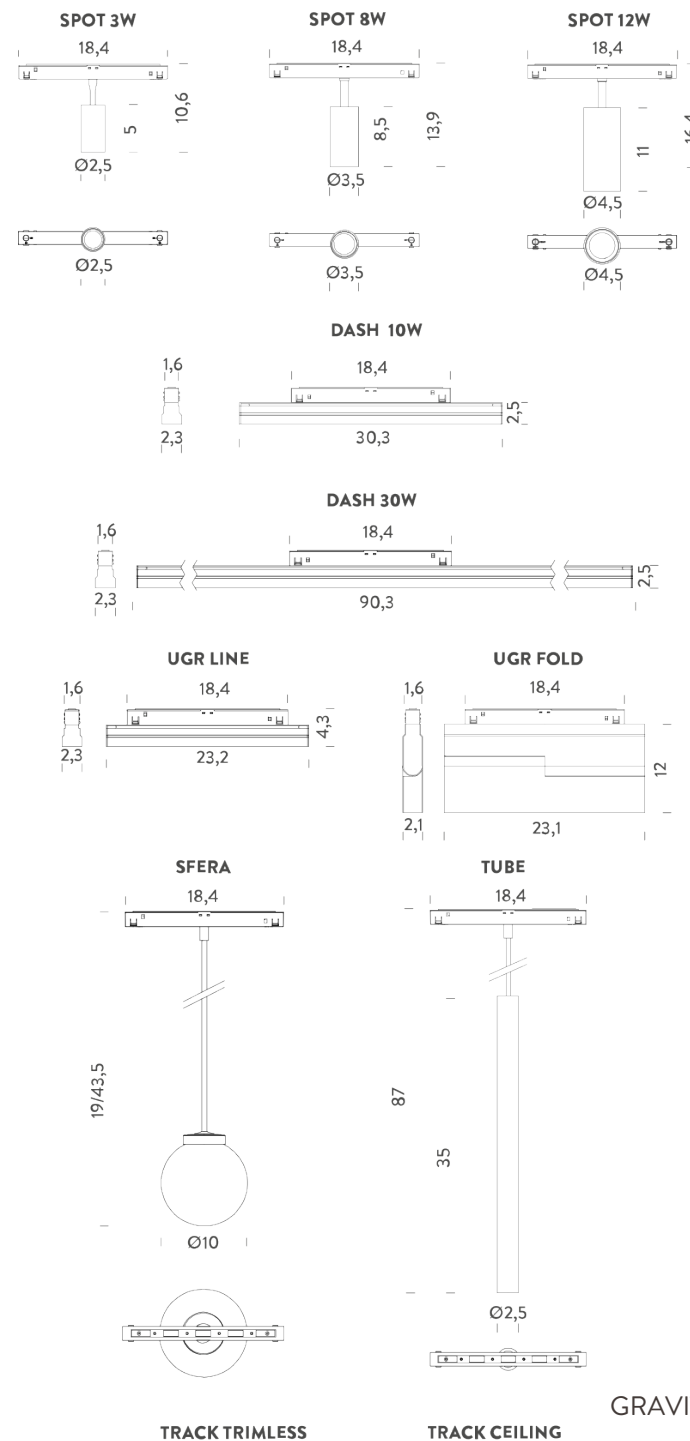

# TRACK CEILING | 2M

## LAMPING

Tension	48V
Dimensions	200x2,6x5,4
Materials	Aluminium
Notes	pendant version available
Customization options	recessed trim version
Accessories	Ceiling-Pendant Track 48V - accessories,   Ceiling-Trimless Track 48V - accessories,
Net lamp weight	1,93 kg

## Codes

MFLE0220NE

## Structure

black

## PACKAGE

Package 01

Dimension: 207x7,5x7,5 cm / Gross weight: 2,59 kg

## Certificazioni

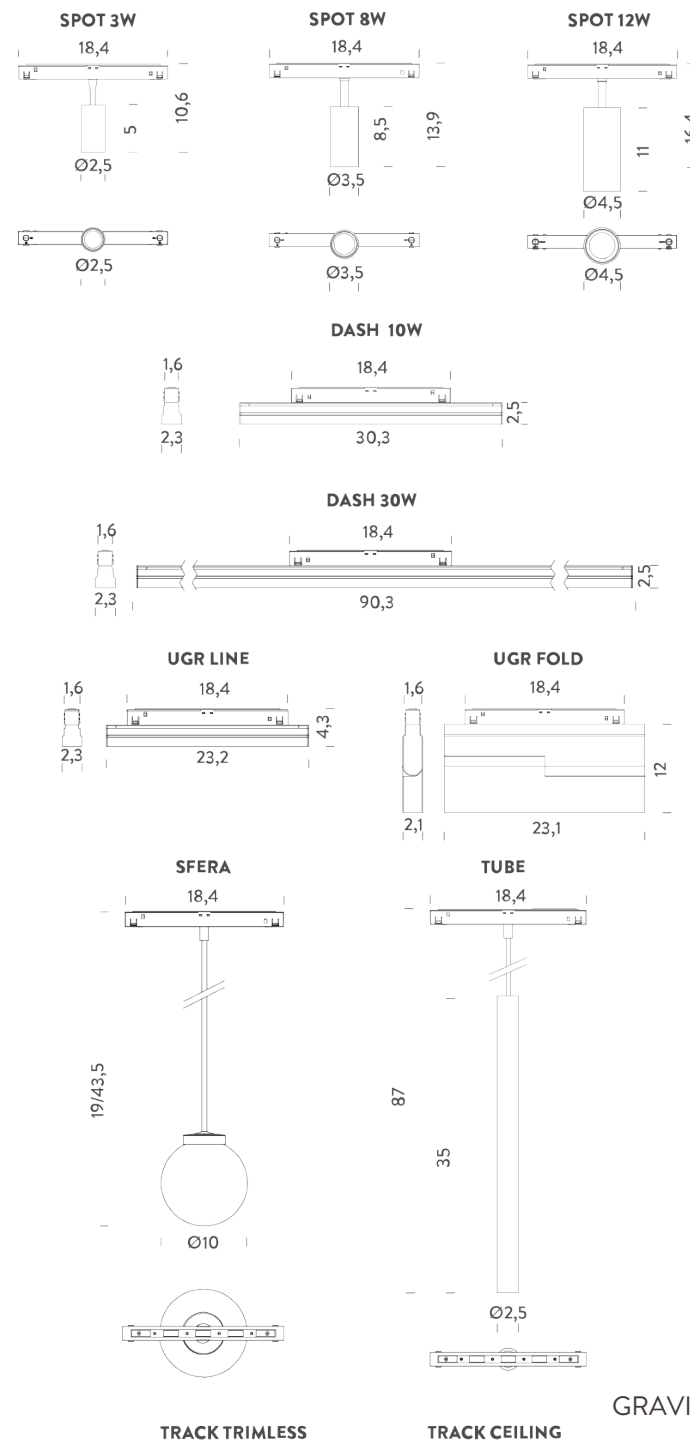

# TRACK CEILING | 3M

## LAMPING

Tension	48V
Dimensions	300x2,6x5x4
Materials	Aluminium
Notes	pendant version available
Customization options	recessed trim version
Accessories	Ceiling-Pendant Track 48V - accessories,   Ceiling-Trimless Track 48V - accessories,
Net lamp weight	2,9 kg

## Codes

MFLE0230NE

## Structure

black

## PACKAGE

Package 01

Dimension: 307x7,5x7,5 cm / Gross weight: 3,87 kg

## Certificazioni

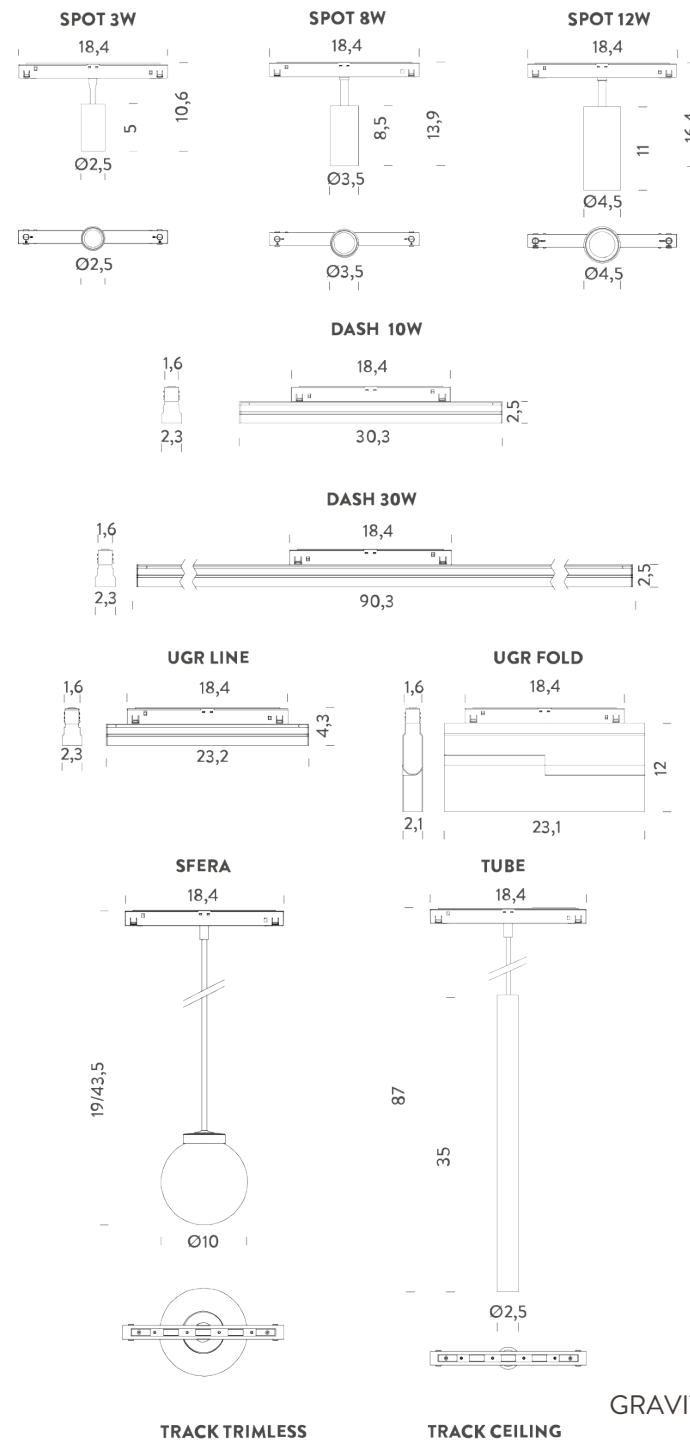

# TRACK TRIMLESS | 1M

## LAMPING

Tension	48V
Dimensions	100x7,4x5,4
Materials	Aluminium
Customization options	recessed trim version
Accessories	Ceiling-Trimless Track 48V - accessories,   Trimless Track 48V - accessories,
Net lamp weight	1,3 kg

## Codes

MFLE0810NE

## Structure

black

## PACKAGE

Package 01

Dimension: 107x9,5x9,5 cm / Gross weight: 1,68 kg

## Certificazioni

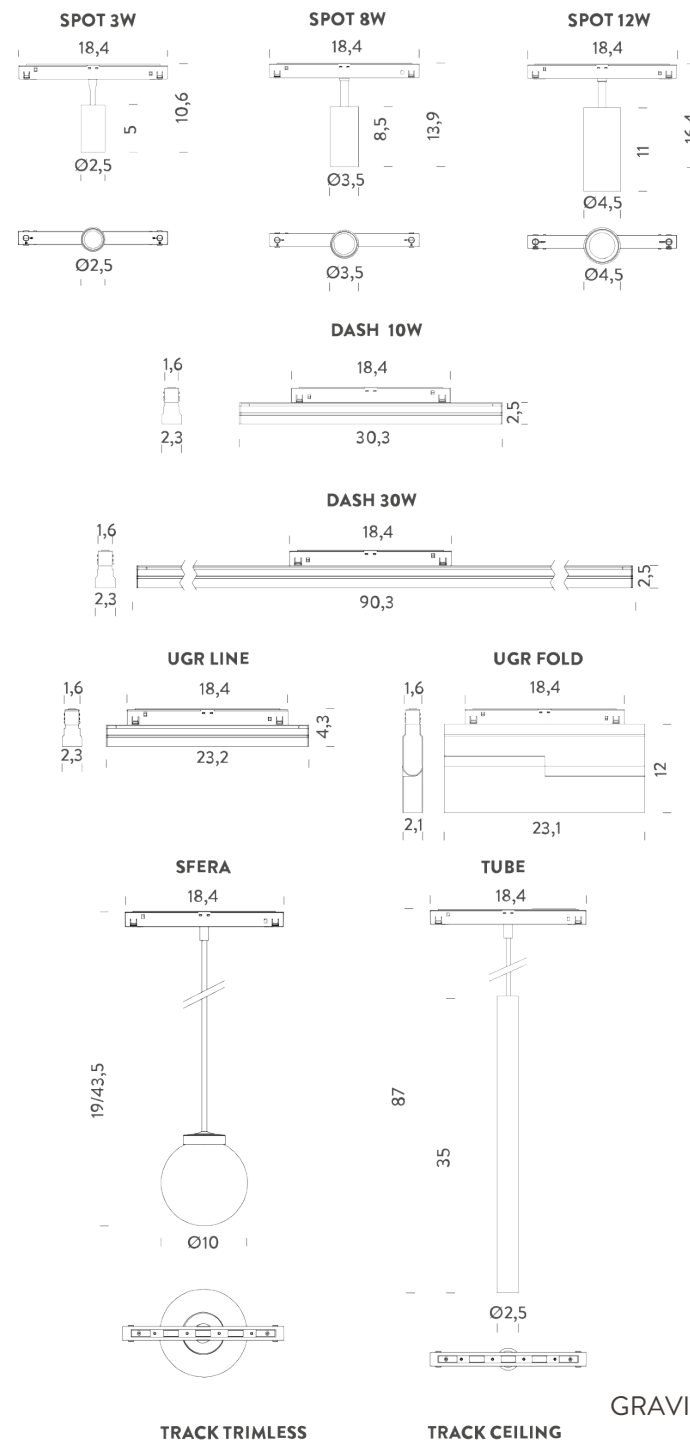

# TRACK TRIMLESS | 2M

## LAMPING

Tension	48V
Dimensions	200x7,4x5,4
Materials	Aluminium
Customization options	recessed trim version
Accessories	Ceiling-Trimless Track 48V - accessories,   Trimless Track 48V - accessories,
Net lamp weight	3 kg

## Codes

MFLE0820NE

## Structure

black

## PACKAGE

Package 01

Dimension: 207x9,5x9,5 cm / Gross weight: 3,65 kg

## Certificazioni

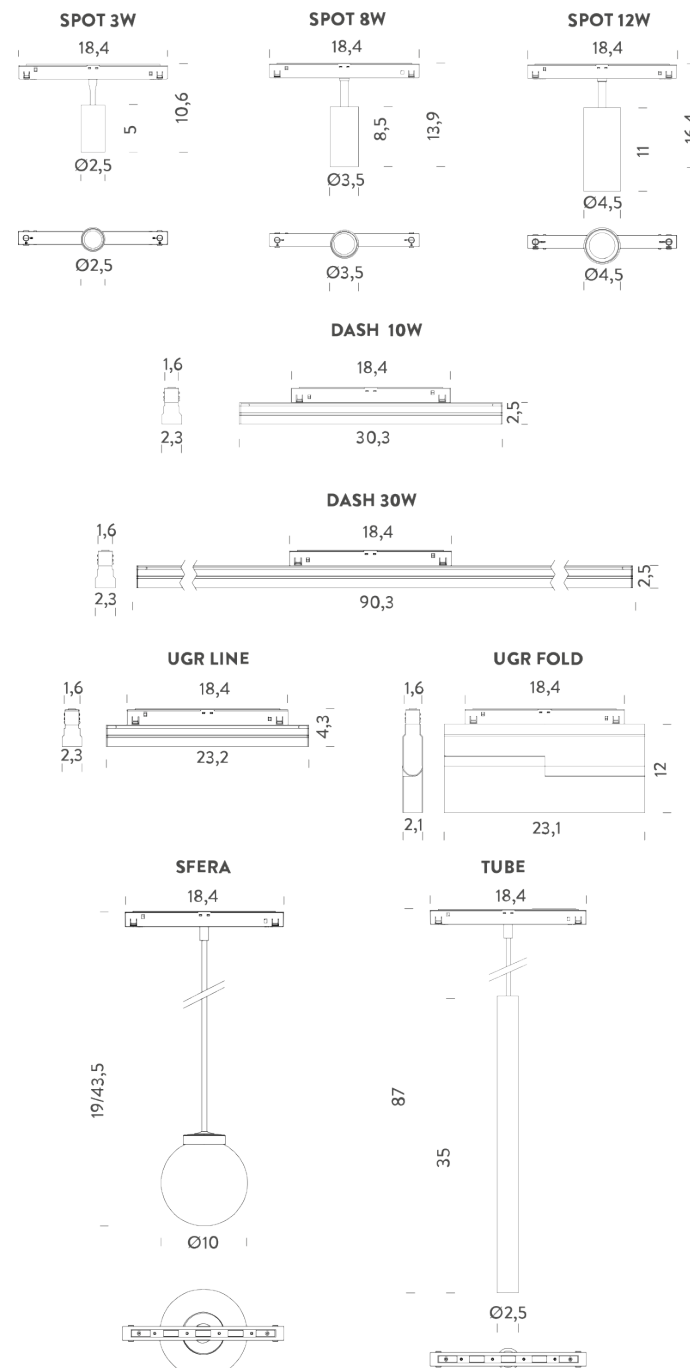

TRACK TRIMLESS

TRACK CEILING

# TRACK TRIMLESS | 3M

## LAMPING

Tension	48V
Dimensions	300x7,4x5,4
Materials	Aluminium
Customization options	recessed trim version
Accessories	Ceiling-Trimless Track 48V - accessories,   Trimless Track 48V - accessories,
Net lamp weight	4,02 kg

## Codes

MFLE0830NE

## Structure

black

## PACKAGE

Package 01

Dimension: 307x9,5x9,5 cm / Gross weight: 5,33 kg

## Certificazioni

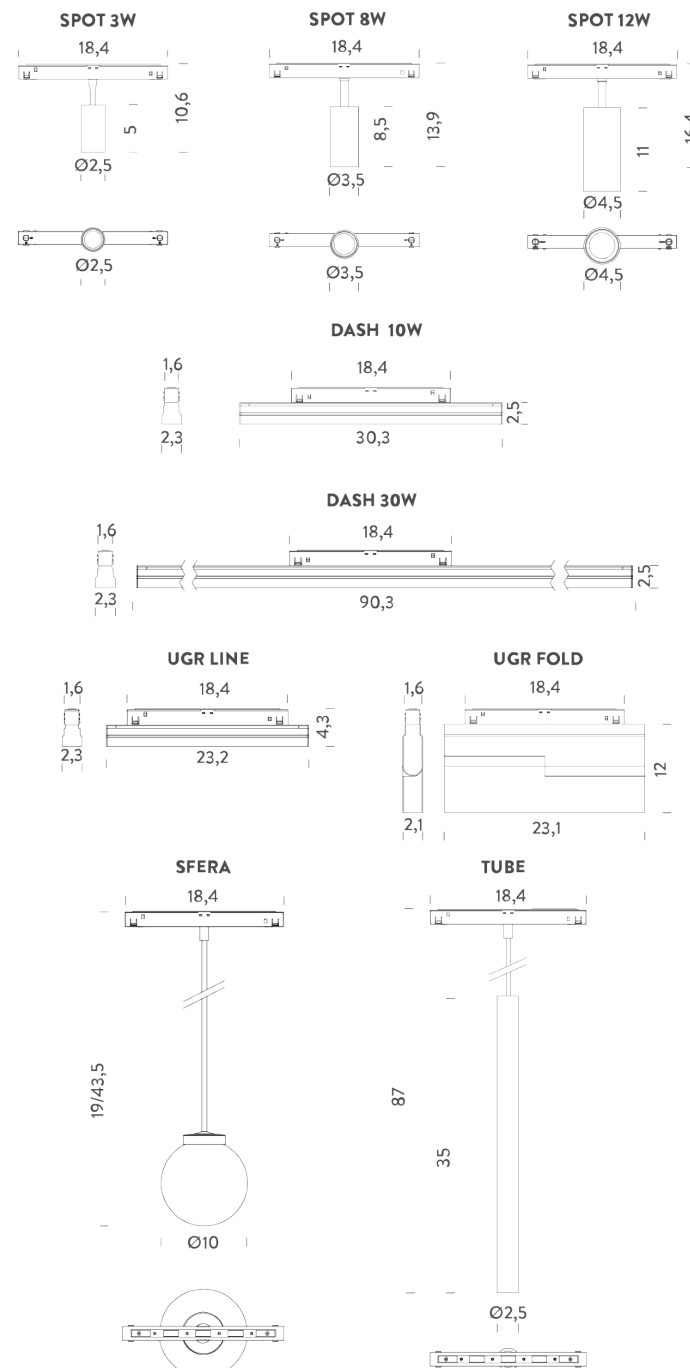

TRACK TRIMLESS

TRACK CEILING