

BROKIS®



TROTTOLA

CM16855

TABLE S, L - PC1323, PC1324



Download

COMPONENTS INCLUDED WITH UNIT:

- 1× light
- 1× power cable with dimmer
- 1× hex key size 1.5
- 1× pair cotton gloves
- 1× installation manual

WARNING:

The manufacturer assumes no liability for damage resulting from incorrect assembly.

When unpacking the light, do so with regard for its material composition – the main components are made of glass.

Wear the cotton gloves included with the light when unpacking and assembling it.

Installation time: 10 minutes / 1 person



BROKIS®

BROKIS S.R.O.
ŠPANILOVA 1315/25
163 00 PRAHA 6 - ŘEPY
CZECH REPUBLIC

ORG. ID 64940799
VAT ID CZ64940799
C 42174 MĚSTSKÝ SOUD
V PRAZE

TEL +420 567 211 517
TECHNICAL@BROKIS.CZ
INFO@BROKIS.CZ
WWW.BROKIS.CZ



CLEANING THE GLASS

BROKIS upholds only the highest possible quality standards. Prior to shipping, the light undergoes several quality controls and stages of cleaning. Because transportation, storage, and the amount of time that passes between packing at our plant and subsequent unpacking by the client can affect the light in different ways, we strongly recommend cleaning it prior to assembly.

The glass must first be rinsed in warm water, and a dish detergent may be used to remove all foreign particles, dust, and grease. Repeat the process if necessary and then dry the glass thoroughly with a paper towel.

Recommendation: Do not use mineral spirits, highly concentrated thinners, or other substances not intended for use on glass surfaces. Do not use any cleaning agents containing silicone, as they may leave a film and attract dust and smudges.

PRIOR TO SHIPPING, THE FUNCTIONALITY OF EACH LIGHT AND ITS COMPONENTS IS THOROUGHLY TESTED. THE MANUFACTURER ASSUMES NO LIABILITY FOR THE MISHANDLING OF PRODUCTS.



1. ASSEMBLING THE LIGHT

Use the hex key size 1.5 to loosen the set screw on the sleeve of the power cable and open the sleeve. Insert the power cable into the connector on the light and replace the sleeve. Retighten the set screw.

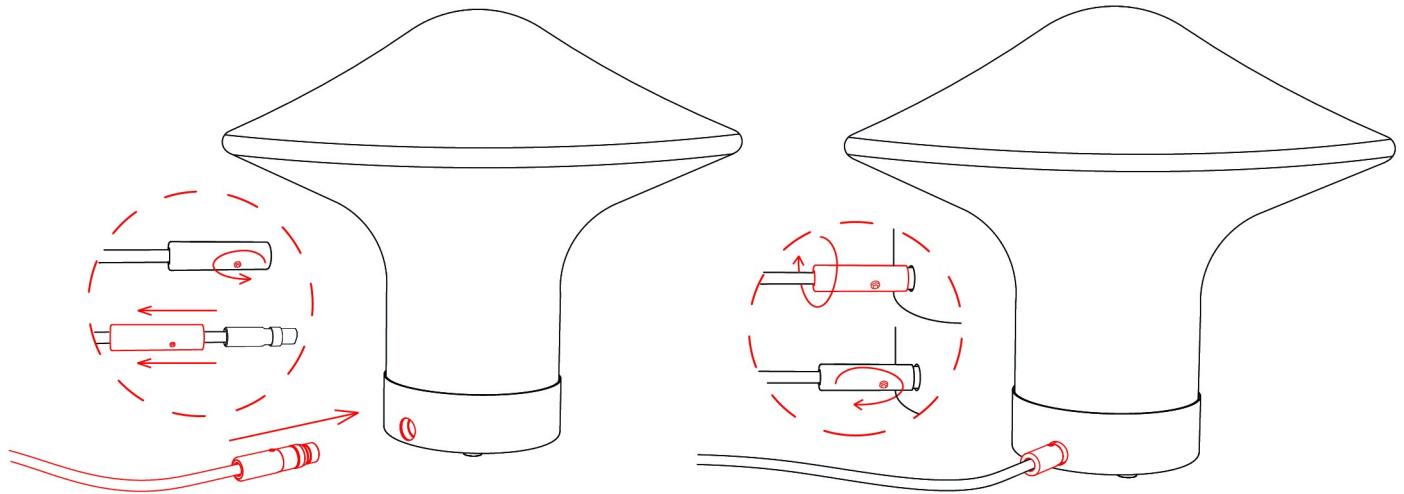

2. SWITCHING ON THE LIGHT

Plug the power cable into an electrical outlet and slide the switch to "On". Ensure the light works properly.

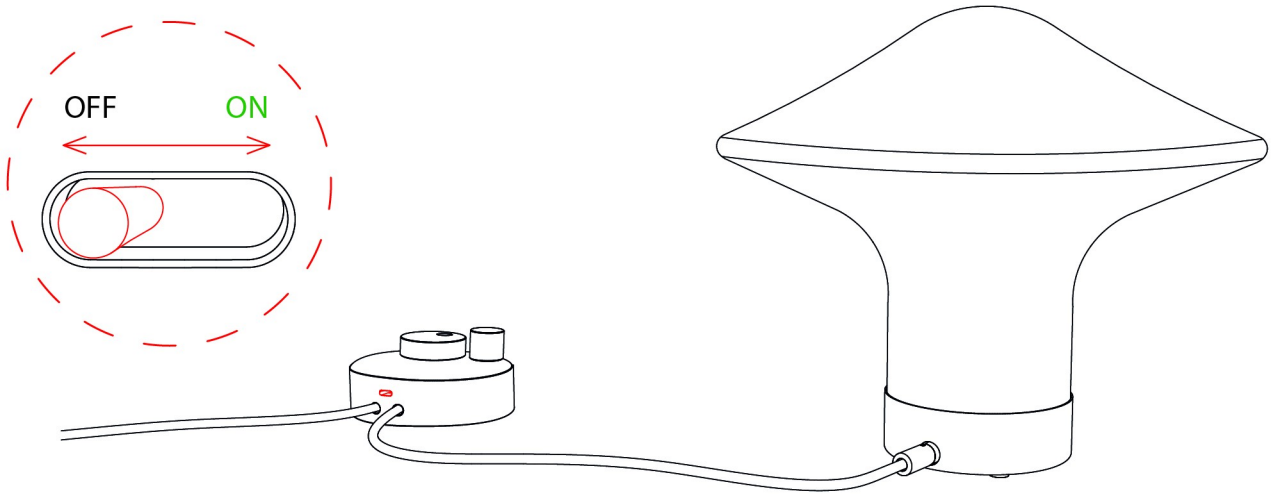

3. DIMMING THE LIGHT

Turn the large dial to increase or decrease the intensity of the light.
Turn the small dial to change the colour temperature.

The dimmer controls only work when the switch is in the "On" position.

