

DATASHEET

Type: **PRISMA**
Name: Pendant light
ID: PC1314
Designed by: Lucie Koldová



Download

Description

The dominant feature of the Prisma collection is an extravagant metal fixture with a distinctive finish. Classic handblown glass spheres are anchored to either one or both ends of a robust decagonal metal prism that lends the collection its name. The shape in combination with the striking surface reflect light at different and unexpected angles, like a prism. With a choice of three different elegant finishes – brushed steel, galvanized yellow zinc gloss, or galvanized yellow zinc matte – the light is a bold artistic object in the interior offering unique vertical, horizontal, and diagonal compositions with subtle colourful reflections. The collection consists of a horizontal pendant light with two dual glass spheres and a vertical pendant light with a single glass sphere, both of which hang from wire ropes. Another typological variant is an impressive floor light, a majestic light sculpture in the form of a robust upright decagon topped with a luminous glass sphere.



Tech. description

The light comes in horizontal and vertical variants. The horizontal variant features dual LED modules with diffusers and glass shades. The vertical variant is fitted to the bottom of a metal fixture. The electronics are concealed within the ceiling canopy.

Colours options: https://brokis.sharepoint.com/:b:/s/brokis_sp/ETSJgLwWwXURBluk3TQ_r5JcByD3TqnUqvq2UcQ4b1AiXgQ

CONSTRUCTION SPECIFICATION

Weight: 6 kg
Construction material: glass, metal
Cord length [mm]: 2,200 mm
Mounting: Ceiling
Environment: Indoor

DIMENSIONS [mm]

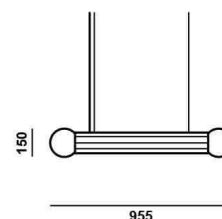

ELECTRICAL SPECIFICATION

Input voltage [V]: 100 - 240 V
Frequency [Hz]: 50-60 Hz
Max. power [W]: 12 W
Coverage IP: 20
Socket: LED module
Light source: -
Energy class: E

CERTIFICATIONS



BROKIS®

BROKIS S.R.O.
ŠPANILOVA 1315/25
163 00 PRAHA 6 - ŘEPY
CZECH REPUBLIC

ORG ID 64940799
VAT ID CZ64940799
C 42174 MĚSTSKÝ SOUD
V PRAZE

TEL +420 567 211 517
TECHNICAL@BROKIS.CZ
INFO@BROKIS.CZ
WWW.BROKIS.CZ

2022_10
PAGE 1

DATASHEET

LED SOURCE



Download

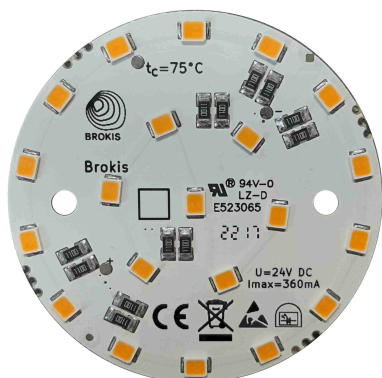

CM15124

Type	LED module
Lamp wattage [W]	6 W
Input voltage [V]	24 VDC
Energy class	E
Flux [lm]	683 lm
Light colour [K]	2700 K
CRI	90+
Dimmable	yes



BROKIS S.R.O.
ŠPANILOVA 1315/25
163 00 PRAHA 6 - ŘEPY
CZECH REPUBLIC

ORG ID 64940799
VAT ID CZ64940799
C 42174 MĚSTSKÝ SOUD
V PRAZE

TEL +420 567 211 517
TECHNICAL@BROKIS.CZ
INFO@BROKIS.CZ
WWW.BROKIS.CZ

2022_10
PAGE 2



INNER FIXTURE

Dimensions O x w [mm] 129 x 70 mm
Weight [kg] 1 kg
Material metal

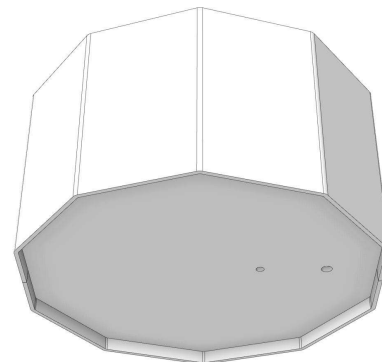

Drawing

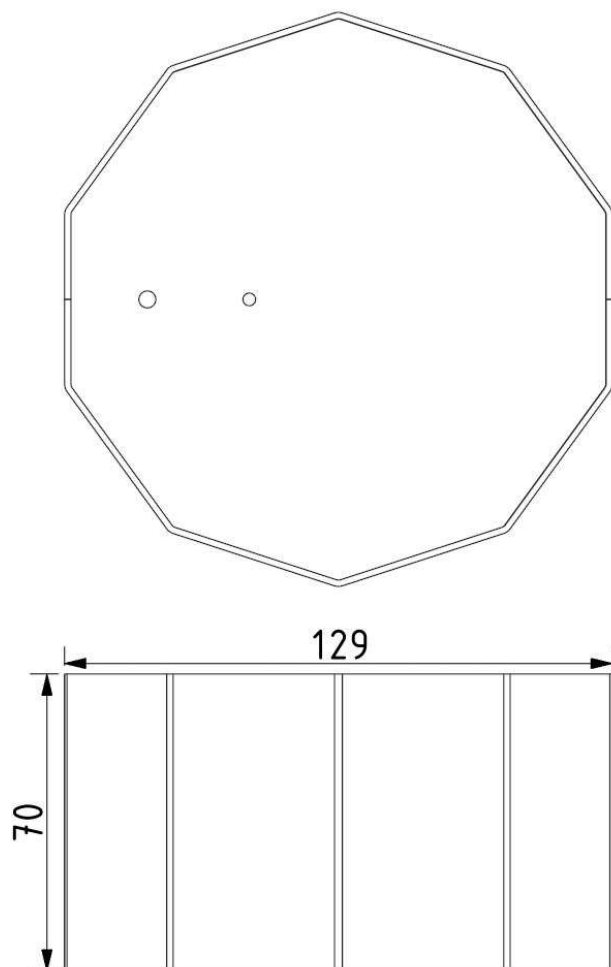

Hole placement

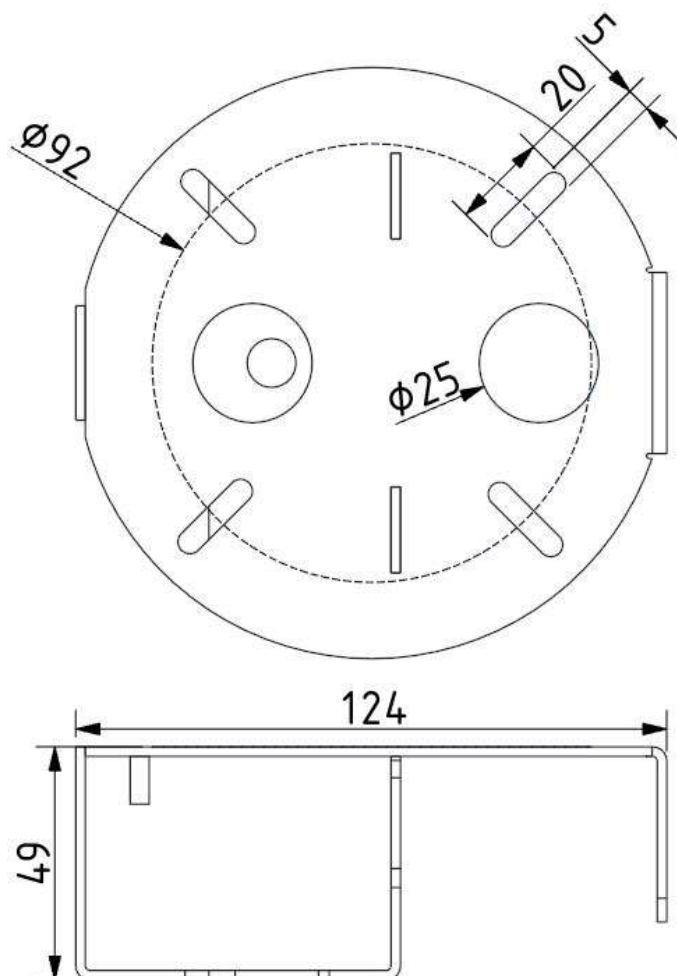



Suspension spacing: 471 mm

Drawing

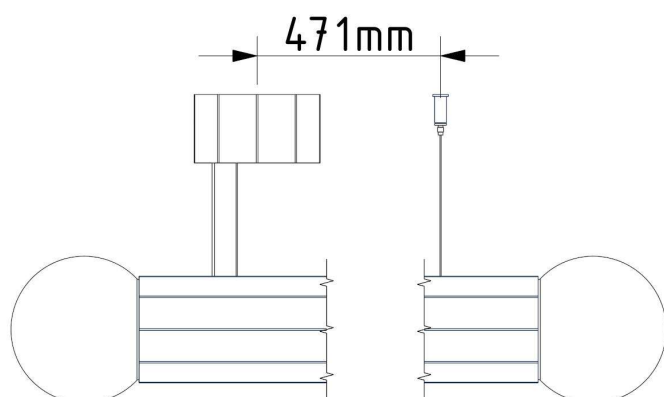

DATASHEET

Type: **PRISMA**
Name: Pendant light
ID: PC1318
Designed by: Lucie Koldová



Download

Description

The dominant feature of the Prisma collection is an extravagant metal fixture with a distinctive finish. Classic handblown glass spheres are anchored to either one or both ends of a robust decagonal metal prism that lends the collection its name. The shape in combination with the striking surface reflect light at different and unexpected angles, like a prism. With a choice of three different elegant finishes – brushed steel, galvanized yellow zinc gloss, or galvanized yellow zinc matte – the light is a bold artistic object in the interior offering unique vertical, horizontal, and diagonal compositions with subtle colourful reflections. The collection consists of a horizontal pendant light with two dual glass spheres and a vertical pendant light with a single glass sphere, both of which hang from wire ropes. Another typological variant is an impressive floor light, a majestic light sculpture in the form of a robust upright decagon topped with a luminous glass sphere.



Tech. description

The light comes in horizontal and vertical variants. The horizontal variant features dual LED modules with diffusers and glass shades. The vertical variant is fitted to the bottom of a metal fixture. The electronics are concealed within the ceiling canopy.

Colours options: https://brokis.sharepoint.com/:b:/s/brokis_sp/Ee4BKOqRzI9EqLjPeU3AHhsBp1Y6m8wp8DjNywMjtQmYTA

CONSTRUCTION SPECIFICATION

Weight: 8.5 kg
Construction material: glass, metal
Cord length [mm]: 2,200 mm
Mounting: Ceiling
Environment: Indoor

DIMENSIONS [mm]

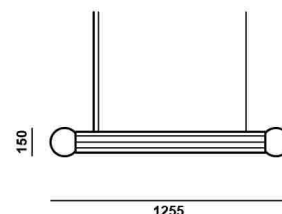

ELECTRICAL SPECIFICATION

Input voltage [V]: 100 - 240 V
Frequency [Hz]: 50-60 Hz
Max. power [W]: 12 W
Coverage IP: 20
Socket: LED module
Light source: -
Energy class: E

CERTIFICATIONS



BROKIS S.R.O.
ŠPANILOVA 1315/25
163 00 PRAHA 6 - ŘEPY
CZECH REPUBLIC

ORG ID 64940799
VAT ID CZ64940799
C 42174 MĚSTSKÝ SOUD
V PRAZE

TEL +420 567 211 517
TECHNICAL@BROKIS.CZ
INFO@BROKIS.CZ
WWW.BROKIS.CZ

2022_10
PAGE 1

DATASHEET

LED SOURCE



Download

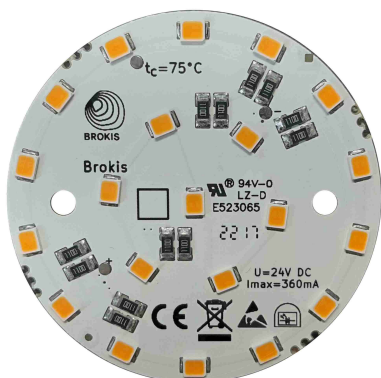

CM15124

Type	LED module
Lamp wattage [W]	6 W
Input voltage [V]	24 VDC
Energy class	E
Flux [lm]	683 lm
Light colour [K]	2700 K
CRI	90+
Dimmable	yes



BROKIS S.R.O.
ŠPANILOVA 1315/25
163 00 PRAHA 6 - ŘEPY
CZECH REPUBLIC

ORG ID 64940799
VAT ID CZ64940799
C 42174 MĚSTSKÝ SOUD
V PRAZE

TEL +420 567 211 517
TECHNICAL@BROKIS.CZ
INFO@BROKIS.CZ
WWW.BROKIS.CZ

2022_10
PAGE 2



INNER FIXTURE

Dimensions O x w [mm] 129 x 70 mm
Weight [kg] 1 kg
Material metal

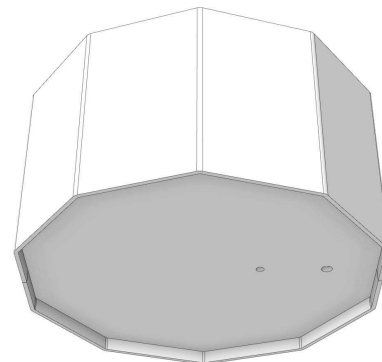

Drawing

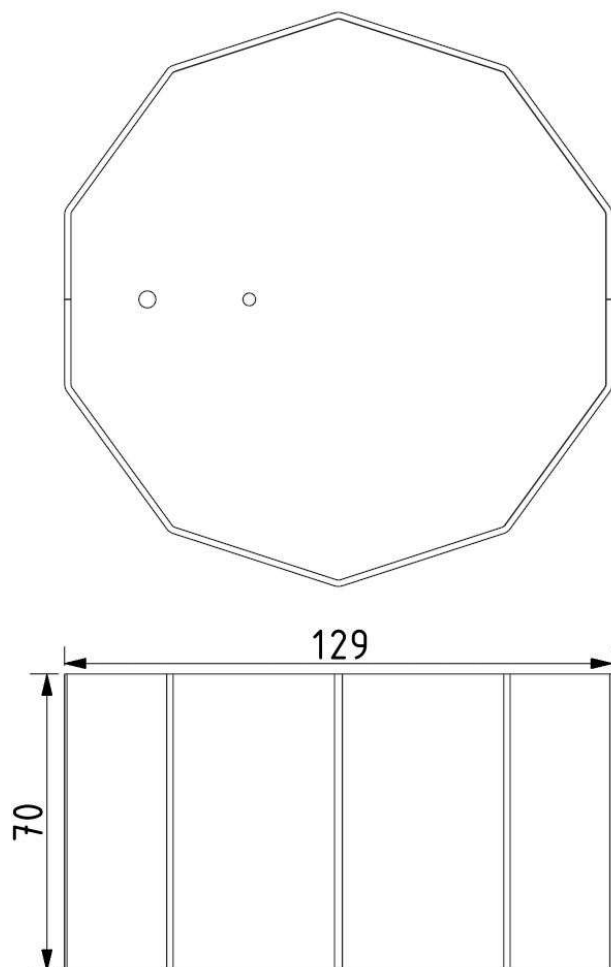

Hole placement

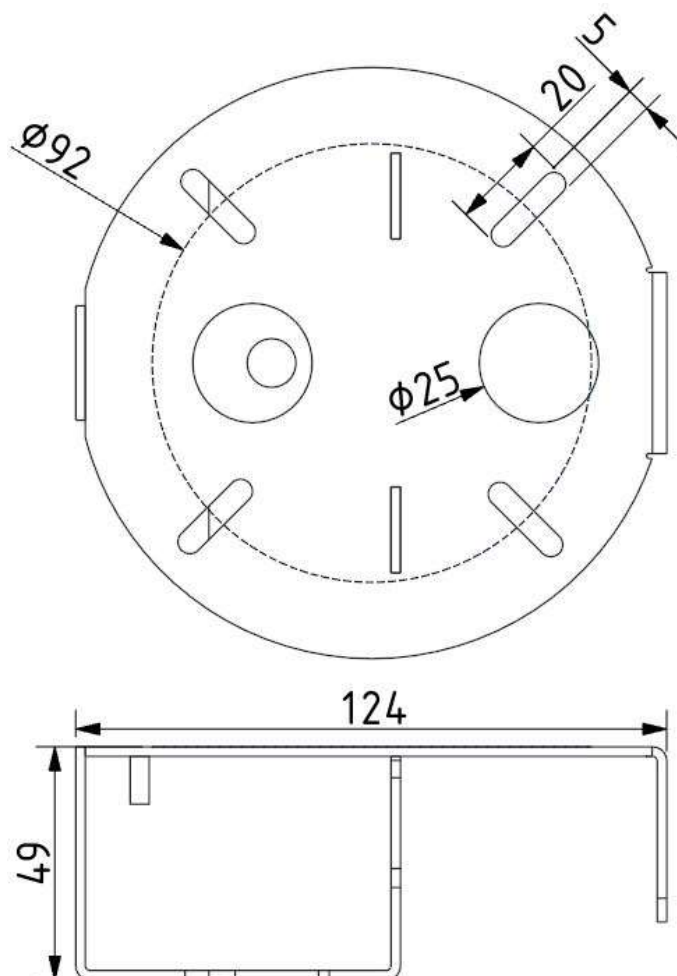



Suspension spacing: 771 mm

Drawing

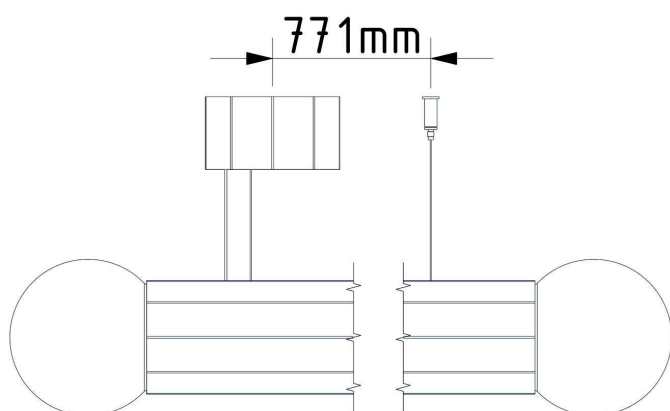

DATASHEET

Type: **PRISMA**
Name: Pendant light
ID: PC1315
Designed by: Lucie Koldová



Download

Description

The dominant feature of the Prisma collection is an extravagant metal fixture with a distinctive finish. Classic handblown glass spheres are anchored to either one or both ends of a robust decagonal metal prism that lends the collection its name. The shape in combination with the striking surface reflect light at different and unexpected angles, like a prism. With a choice of three different elegant finishes – brushed steel, galvanized yellow zinc gloss, or galvanized yellow zinc matte – the light is a bold artistic object in the interior offering unique vertical, horizontal, and diagonal compositions with subtle colourful reflections. The collection consists of a horizontal pendant light with two dual glass spheres and a vertical pendant light with a single glass sphere, both of which hang from wire ropes. Another typological variant is an impressive floor light, a majestic light sculpture in the form of a robust upright decagon topped with a luminous glass sphere.



Tech. description

The light comes in horizontal and vertical variants. The horizontal variant features dual LED modules with diffusers and glass shades. The vertical variant is fitted to the bottom of a metal fixture. The electronics are concealed within the ceiling canopy.

Colours options: https://brokis.sharepoint.com/:b/s/brokis_sp/ETxs6S92unRNhHU-cg_qroMBZ8dGAnCgx8N1U_12MJIPHw

CONSTRUCTION SPECIFICATION

Weight: 10.5 kg
Construction material: glass, metal
Cord length [mm]: 2,200 mm
Mounting: Ceiling
Environment: Indoor

DIMENSIONS [mm]

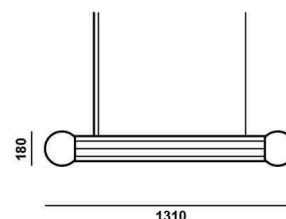

ELECTRICAL SPECIFICATION

Input voltage [V]: 100 - 240 V
Frequency [Hz]: 50-60 Hz
Max. power [W]: 12 W
Coverage IP: 20
Socket: LED module
Light source: -
Energy class: E

CERTIFICATIONS



BROKIS S.R.O.
ŠPANIĚLOVA 1315/25
163 00 PRAHA 6 - ŘEPY
CZECH REPUBLIC

ORG ID 64940799
VAT ID CZ64940799
C 42174 MĚSTSKÝ SOUD
V PRAZE

TEL +420 567 211 517
TECHNICAL@BROKIS.CZ
INFO@BROKIS.CZ
WWW.BROKIS.CZ

2022_10
PAGE 1

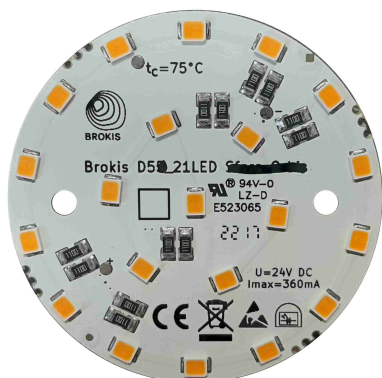

CM15124

Type	LED module
Lamp wattage [W]	6 W
Input voltage [V]	24 VDC
Energy class	E
Flux [lm]	683 lm
Light colour [K]	2700 K
CRI	90+
Dimmable	yes



INNER FIXTURE

Dimensions O x w [mm] 129 x 70 mm
Weight [kg] 1 kg
Material metal

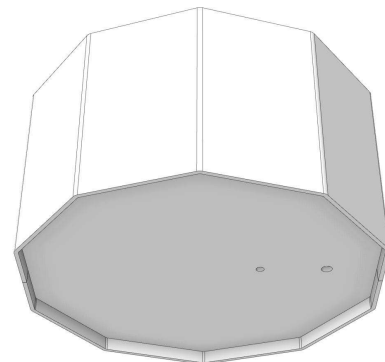

Drawing

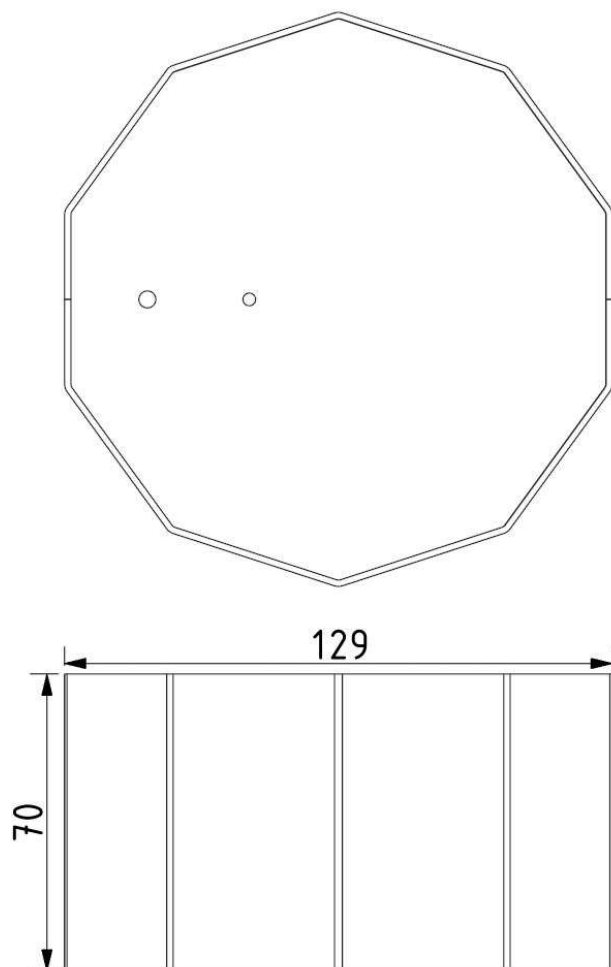

Hole placement

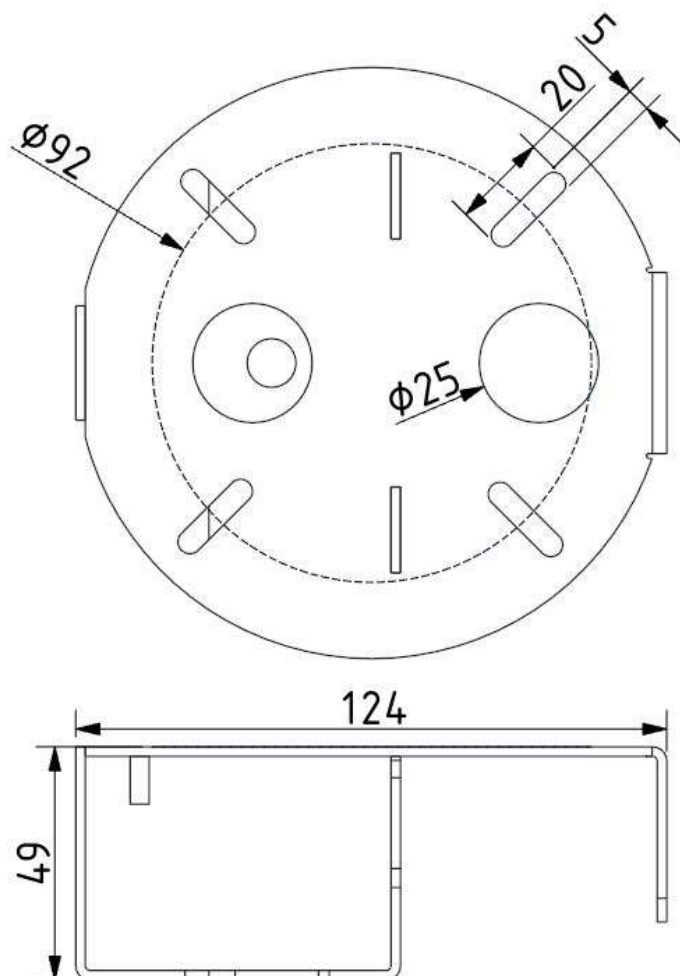



Suspension spacing: 746 mm

Drawing

