

MICHAELANASTASSIADES

INSTALLATION INSTRUCTIONS



MOBILE CHANDELIER 2, 2008

## PRODUCT SPECIFICATIONS

Integrated LED, 9W for Ø 150mm sphere

120V / 240V dimmable 0~10Vdc or 10V PWM signal or resistance

Product weight: ~15kg

## BEFORE INSTALLING

Please keep these instructions for future reference.

Please read instructions in full prior to installation noting all illustrations. Instructions should be followed precisely.

Two people are needed to assemble this light.

Always wear the gloves provided when handling the fixture.

If you are in any doubt, consult a qualified electrician to install the fitting.

Install in accordance with current national or local wiring regulations.

Ensure the circuit, to which the fitting is to be connected, has been installed and fused in accordance with local electrical standards.

Disconnect the electrical supply at the fuse box. Switching off via a wall switch is not adequate.

The fitting is for use in a normal dry domestic indoor environment. Suitable for mounting on non-combustible surfaces only.

If removing an existing fitting, carefully note all wiring connections and record which of the wires is connected to which terminal.

Carefully identify the supply cable. Check there are no other cables in the area to avoid damage to concealed wiring during installation.

Please make sure the wires are matching to the correct connectors according to live, neutral or earth (ground).

Position the light where desired, ensuring that the area is suitable to support the weight of the light.

Determine the fixing method appropriate to the surface material.

Modifying any part of the light will void the products warranty.

Michael Anastassiades accepts no liability for incorrect use of the mentioned object.

## BLACK PATINATED BRASS

The black brass patina is achieved through an artisanal technique of applying pigments by hand during a hot patination process. Through this alchemic process, the brass is transformed whilst retaining the material's inherent qualities. It will mature and change over time. The manner and speed in which it will change will depend on the environment, handling and the level and frequency of maintenance. Verdigris can also appear when the copper in the brass begins to oxidise.

## CLEANING INSTRUCTIONS

Before cleaning, lighting fixtures must be turned off and unplugged from mains electricity. Whilst cleaning please take care and use the gloves provided.

Black patinated: Use a dry soft dust cloth and gently go over marks until clean.

Opaline glass: Remove the opaline glass from the product. Using a lightly damp cloth, clean only the outside of the sphere. Only put the glass sphere back on the product once it is fully dry.

## Parts Supplied

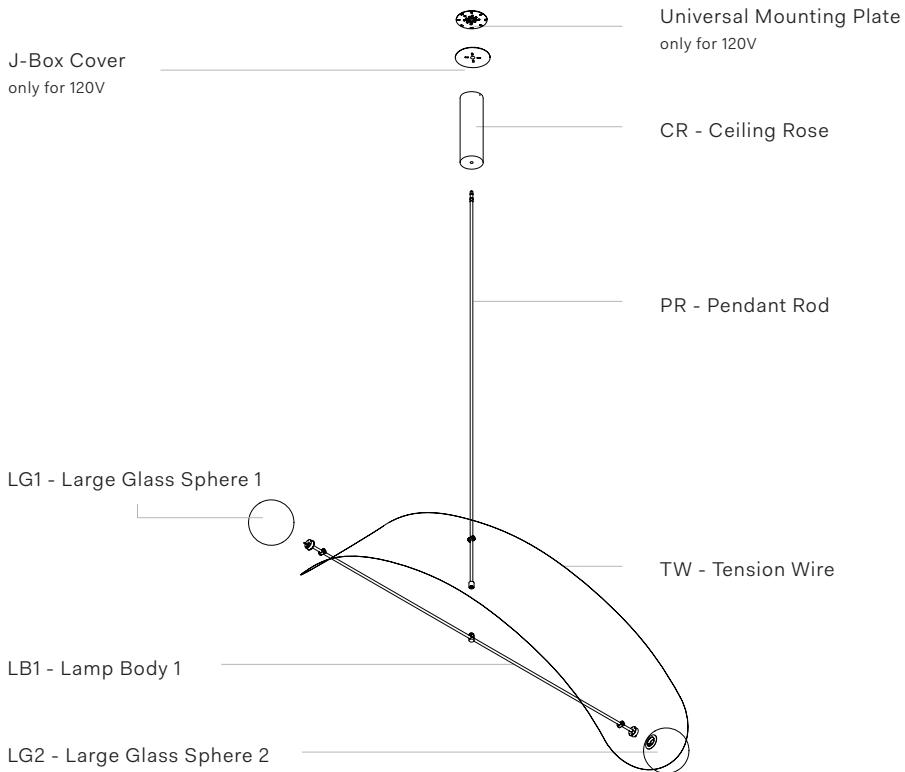

## Additional Items Provided

Pair of Gloves  
Spare Kit Bag

## Additional Requirements

Power Drill and Bits  
Mounting Screws and Ceiling Anchors

Fig. 1

Whilst installing the fixture please take care and use the gloves provided.

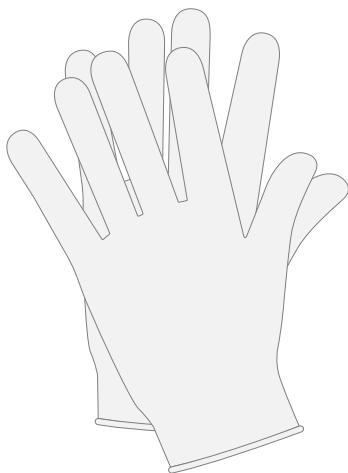

Black patina is a live finish. If the product has tarnished in transit, use the soft cloth provided and gently rub the fixture to restore the patina.

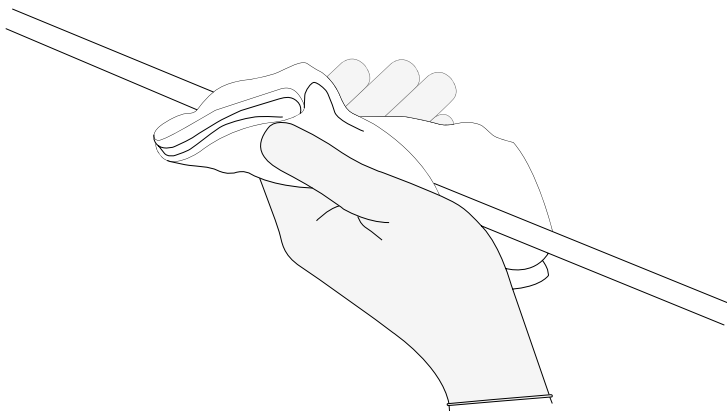

Fig. 2

Using the supplied hex key unlock the grub screw on the Ceiling Rose (A). Whilst using gloves carefully unscrew the Ceiling Bracket Assembly (B) from the Ceiling Rose (A).

Do not unscrew the grub screw all the way out.

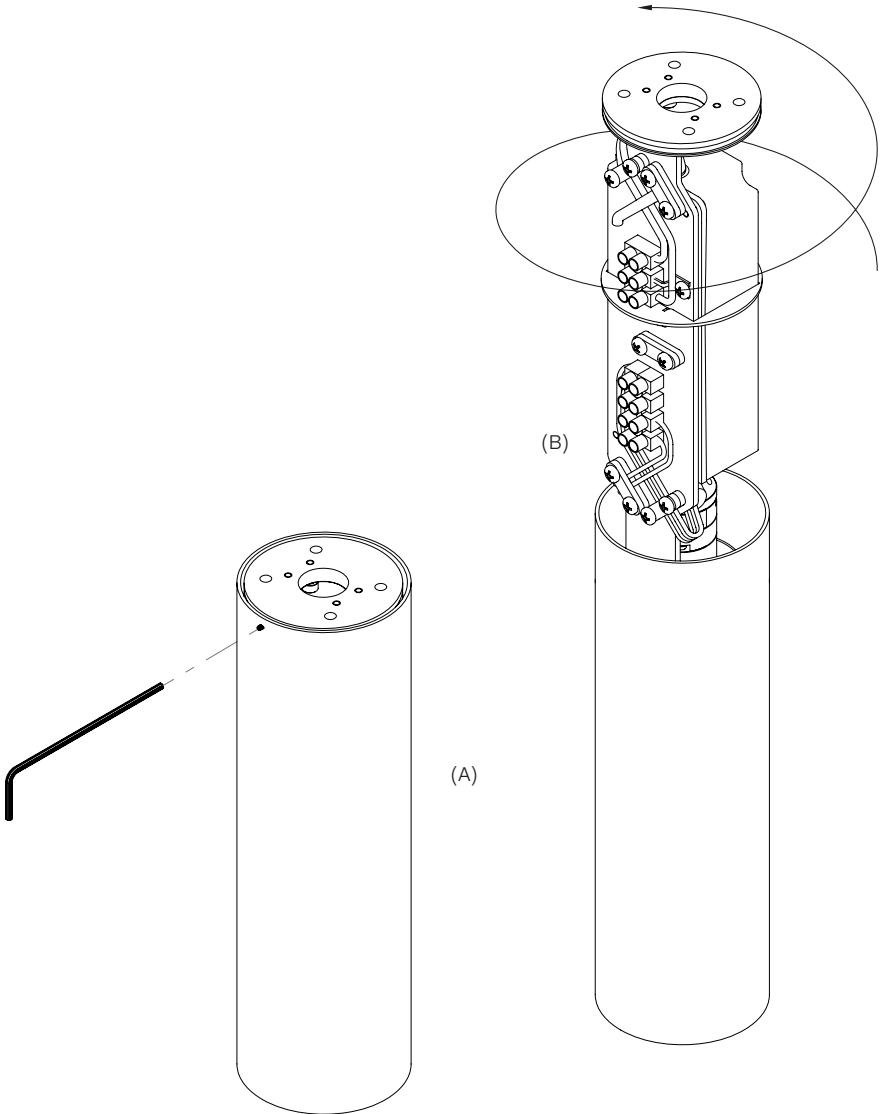
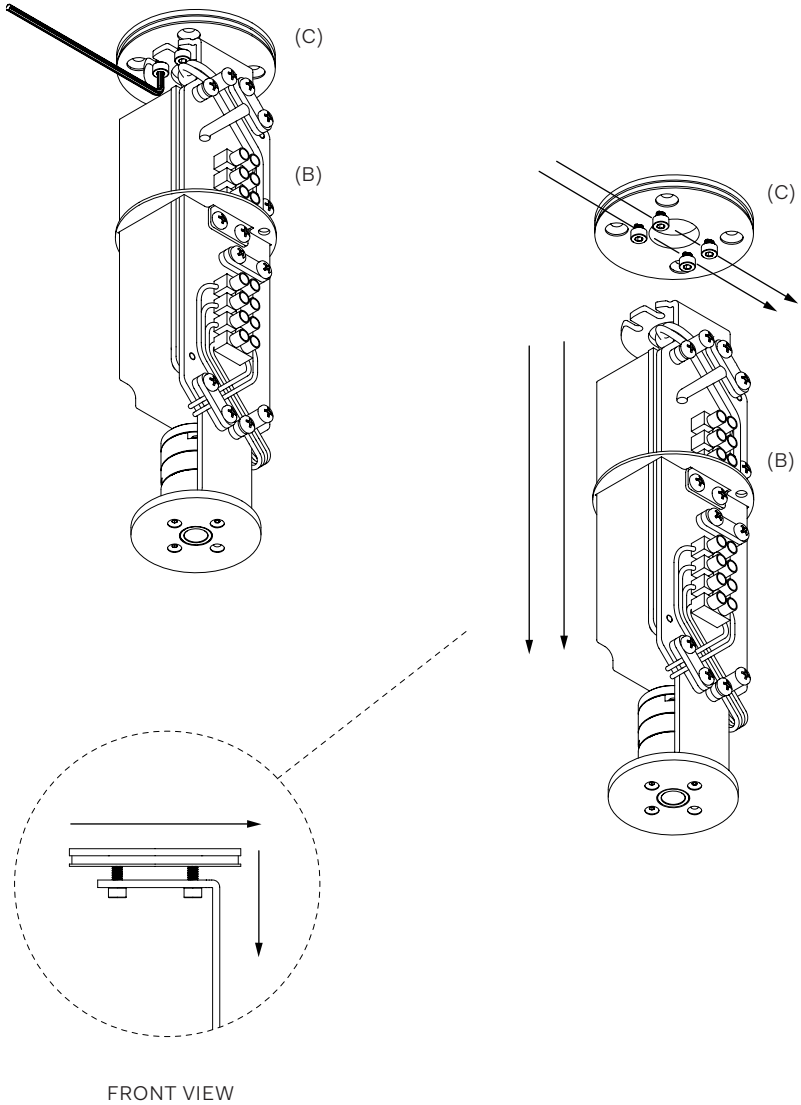

Fig. 3

Using the supplied hex key, loosen the four screws attaching the Ceiling Plate (C) to the Ceiling Bracket (B). Slide the Ceiling Plate (C) away from the Ceiling Bracket (B).





### Fig. 4 For 240V Fittings

Place the Ceiling Plate (C) onto the ceiling, centre it to the mains electrical supply cable and mark four holes to be drilled. Once drilled, insert wall anchors into the holes, ensuring that the area is able to support the entire weight of the fixture (noted on product specification). Screw the Ceiling Plate (C) onto the wall, making sure it is levelled.

Wall anchors and mounting screws are not supplied for this fixture. Determine the fixing method appropriate to the surface material before starting the project. Use fixings that are suited to the surface material and are sufficient to bear the weight of the light.

Go to Fig. 7 for next step.

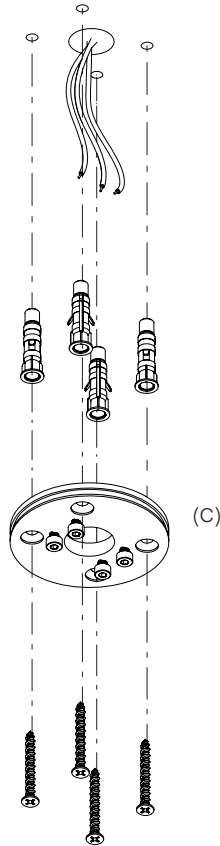
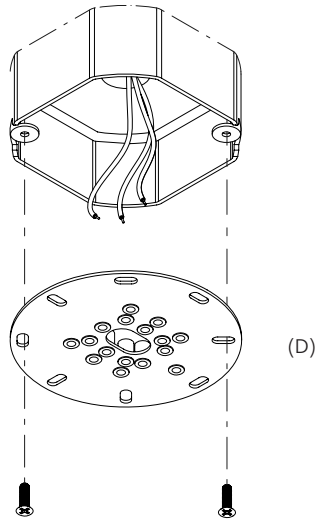

Fig. 5 For 120V Fittings

Screw the Universal Mounting Plate (D) onto the junction box, making sure it is levelled. Pull live, neutral and ground cables out through the central hole. Mounting screws are not supplied with this fixture as J-boxes can vary.



Note: Make sure the supplied Universal Mounting Plate is fastened directly to the junction box. The surface of the junction box should be set back 1/8" or 3mm from the mounting surface. This will ensure the best possible fit for ease of installation and final finish. Note below the correct and incorrect fit for optimum installation.

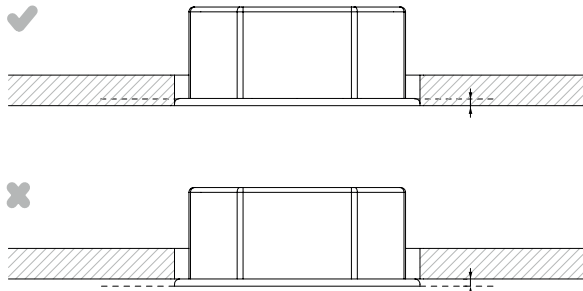
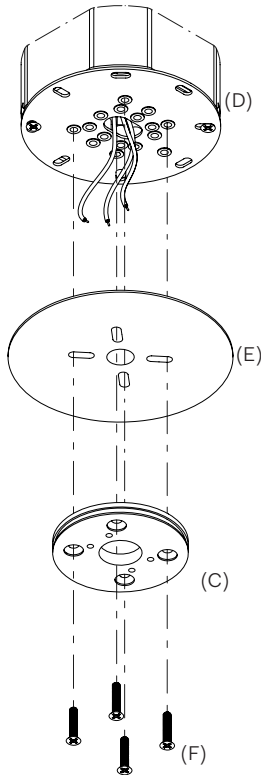

Fig. 6 For 120V Fittings

Feed the electrical cables through the central hole of the Junction Box Cover (E) and the Ceiling Plate (C). Use screws supplied (F) to secure Junction Box Cover (E) and Ceiling Plate (C) on the Universal Mounting Plate (D).



Paint over the J-box cover to match the wall finish.

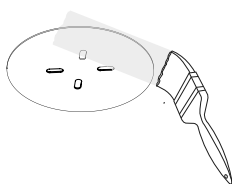

Fig. 7

Carefully pass the supply wires through the central hole of the Ceiling Bracket (B). Slide the Ceiling Bracket (B) onto the Ceiling Plate (C). Supporting the Ceiling Bracket (B), ensuring it is fully aligned with the Ceiling Plate (C), tighten the four cap head screws with the supplied hex key.

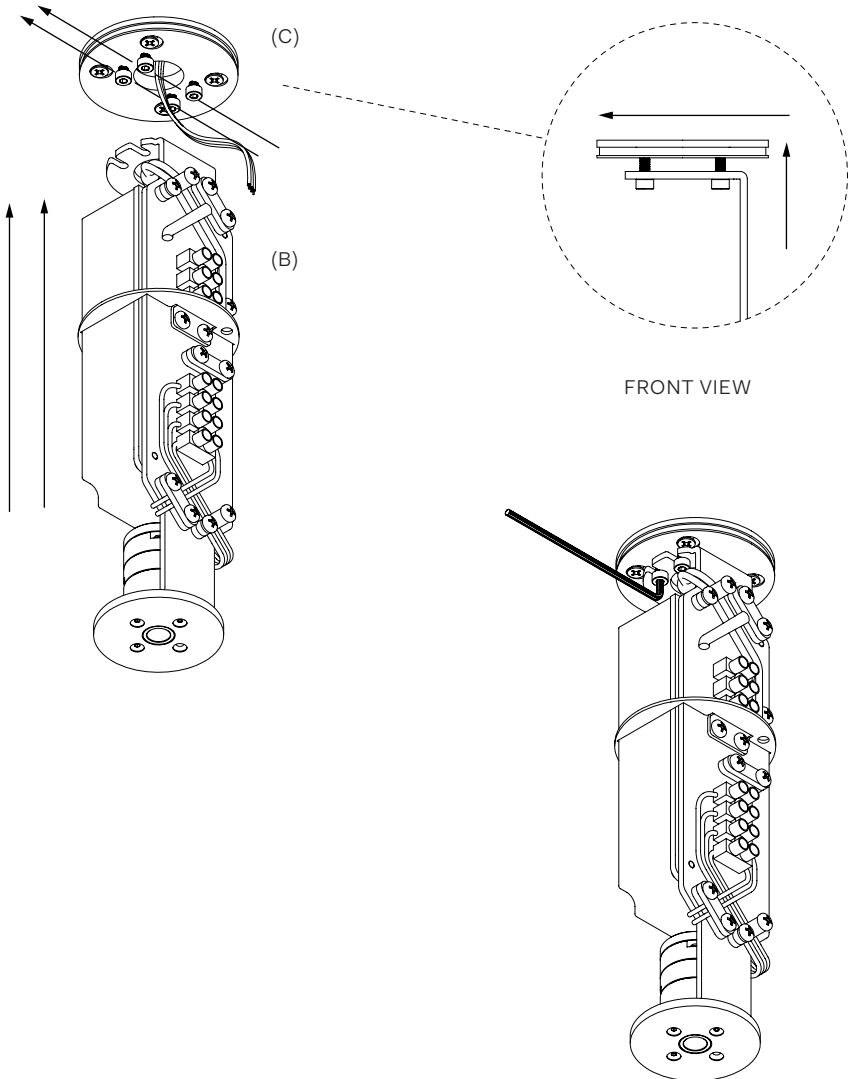

Fig. 8

Carefully pull the supply wires ensuring there is no excess wire. Secure them using the Wire Grip (G), leaving enough wire to be able to reach the Terminal Block (H).

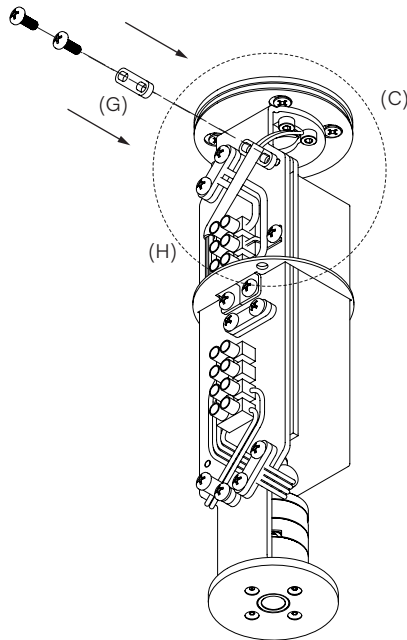
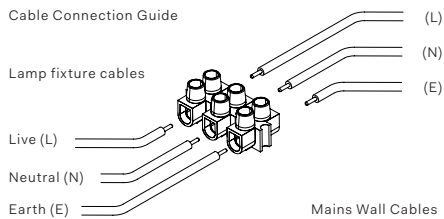
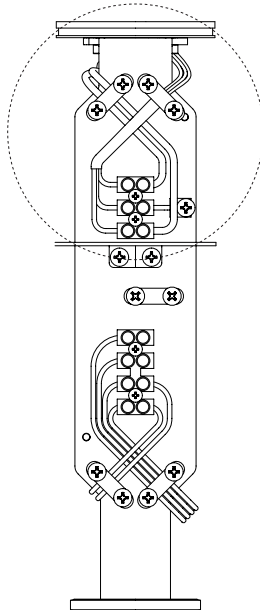

Fig. 9

Connect the live, neutral and earth of the mains electrical cable to the terminal block of the fixture. Make sure all electrical cables match correctly.

See Cable Connection Guide for further reference.



### Fig. 10 For Dimming (Optional)

The light uses a 3-1 Dimming System: it can be dimmed using 0-10VDC, additive 10V PWM or Additive Resistance dimming devices.

(Driver technical data sheet is available on request. Refer to the 'Dimming Operation' page).

To connect the dimmer to the dimming circuit of the light, locate the Terminal Block (I) on the rear of the Ceiling Bracket (B). The Blue Wire represents the positive (DIM+) side of the dimming circuit, and the White Wire represents the negative (DIM-) side of the circuit. Connect the (DIM+)(BLUE) to the Positive wire of the dimmer, and connect the (DIM-)(WHITE) to the negative wire of the dimmer, using the Terminal Block (I).

Secure the dimming wires using the Cable Clamp (J).

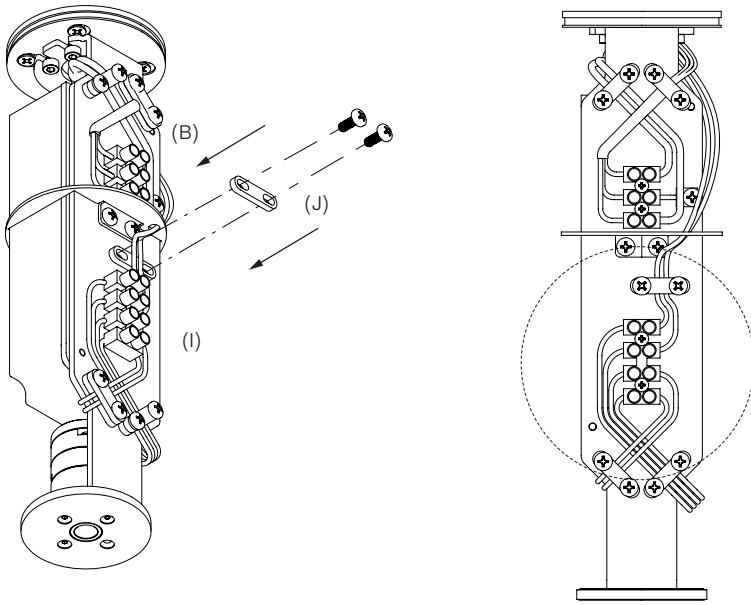

#### Cable Connection Guide

Lamp fixture cables

Dim + (Blue)

Dim - (White)

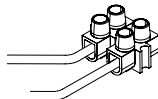

Dim +  
Dim -

Dimming Control Cables

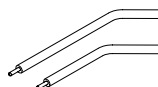
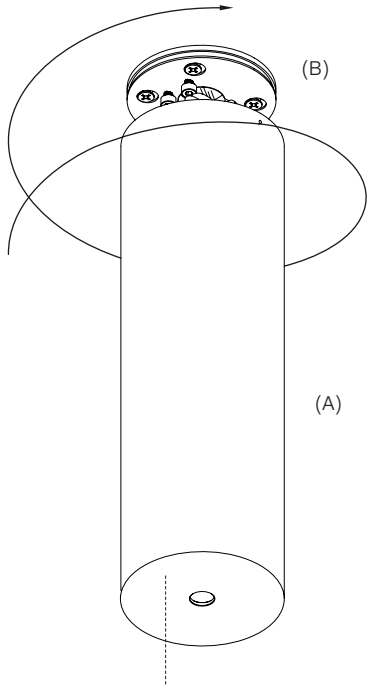

Fig. 11

Ensure all wires are neatly secured. Using gloves, carefully slide the Ceiling Rose (A) over the Ceiling Bracket (B), then gently thread the Ceiling Rose (A) onto the threaded boss on the Ceiling Bracket (B). Using the supplied hex key, re-tighten the grub screw to lock the Ceiling Rose (A) in place.



Internal thread located in this position

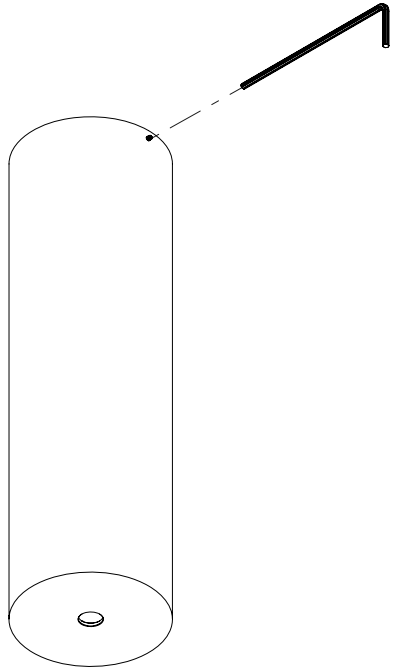



Fig. 12

On a soft surface, using gloves, secure the Large Glass Sphere 1 (K) onto the Lamp Body 1 (L). Carefully rotate the Large Globe (K) onto the Male Glass Connector (M) until the internal location pins are aligned. Gently push the Large Glass Sphere 1 (K) onto the pins until the outside faces of the Large Female Glass Connector (N) and Large Male Glass Connector (M) sit flush.

Secure the Large Glass Sphere 1 (K) with the supplied M2×20 screw and hex key, ensuring it is tight to keep the connectors flush. See Fig.13.

Repeat the same process for the Large Glass Sphere 2 (O)

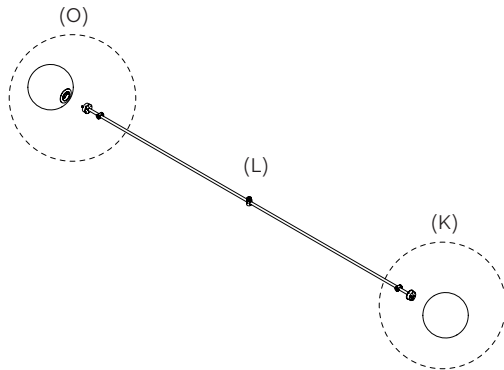

Fig. 13

Carefully rotate the Large Glass Sphere 1 (K) on the Large Male Glass Connector (M) until the internal location pins are aligned. Gently push the Large Glass Sphere 1 (K) onto the pins until the outside faces of the Large Female Glass Connector (N) and Large Male Glass Connector (M) sit flush.

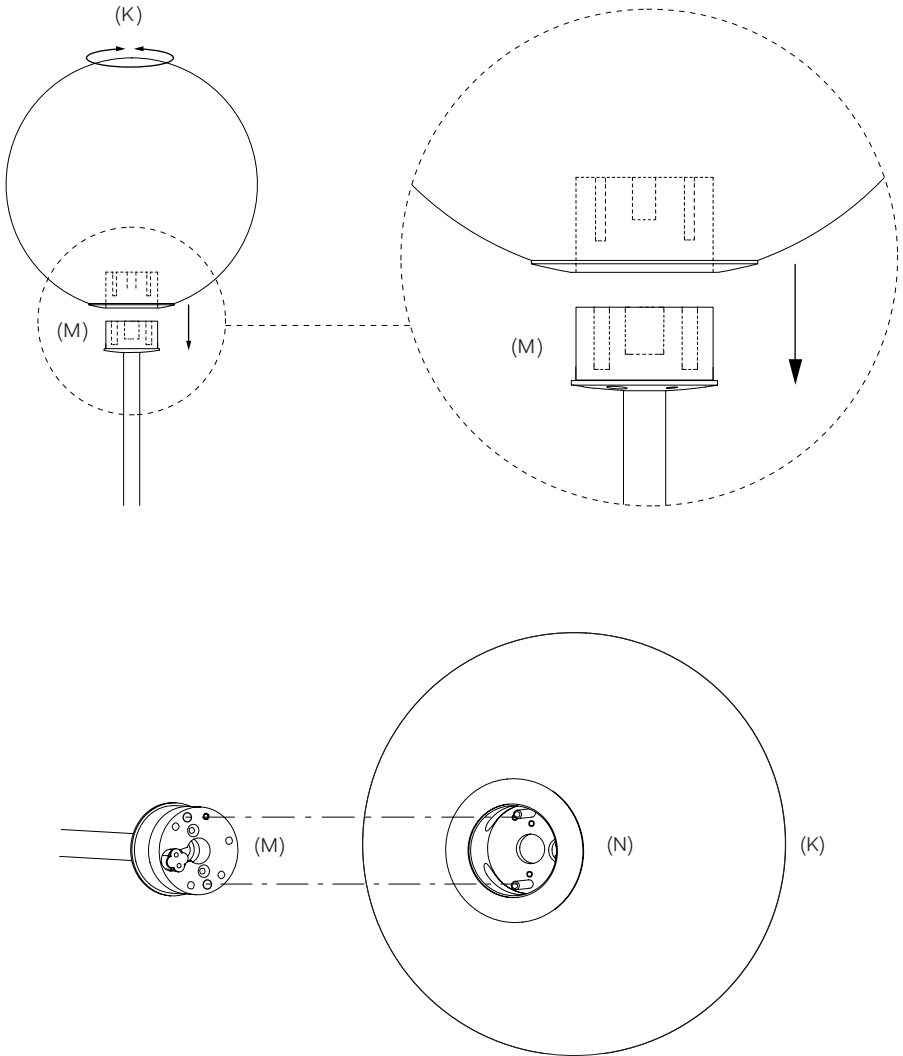

Fig. 14

Secure the Large Glass Sphere 1 (K) with the supplied M2×20 screw and hex key, ensuring it is tight to keep the connectors flush.

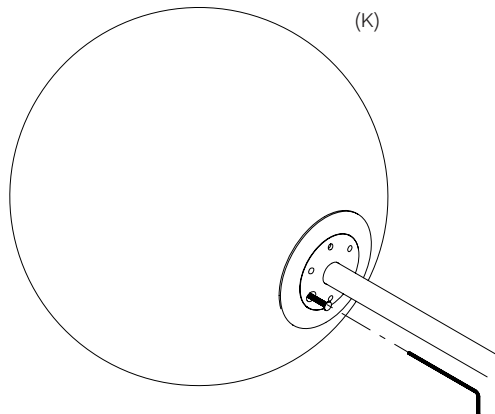
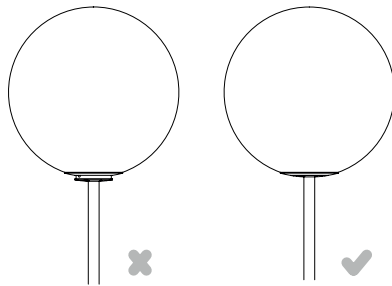

Fig. 15

Using gloves, carefully insert the Pendant Rod (U) into the Ceiling Rose (A). Whilst applying upward pressure, gently turn the Pendant Rod (U) clockwise until you feel a small click. This is the clutch engaging. It will feel as if the Pendant Rod has locked but keep gently twisting until it will not twist any further then carefully release the Pendant Rod (U). It will feel like it drops slightly. This is the clutch disengaging and the Pendant Rod will now rotate freely.

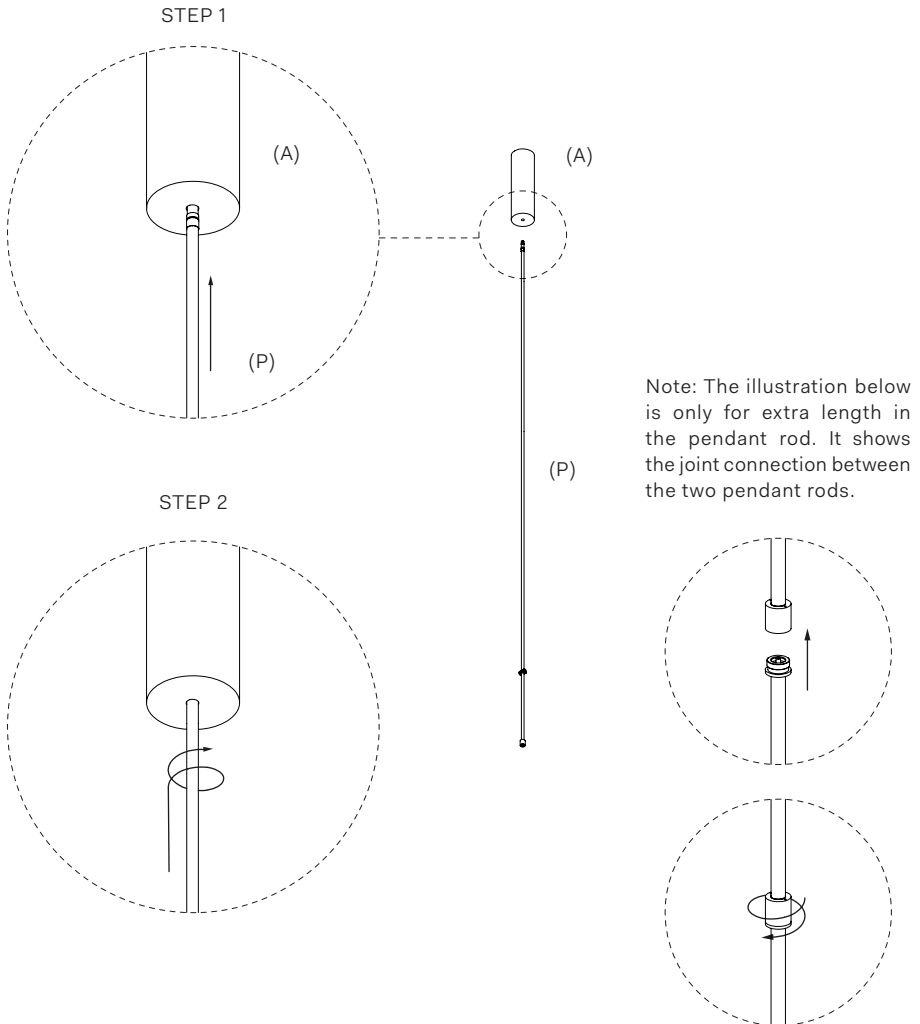

Fig. 16

Using gloves, support the Lamp Body 1 (L) and carefully insert the Joint Boss (Q) into the Pendant Rod Cap (R). Gently screw them together until tight.

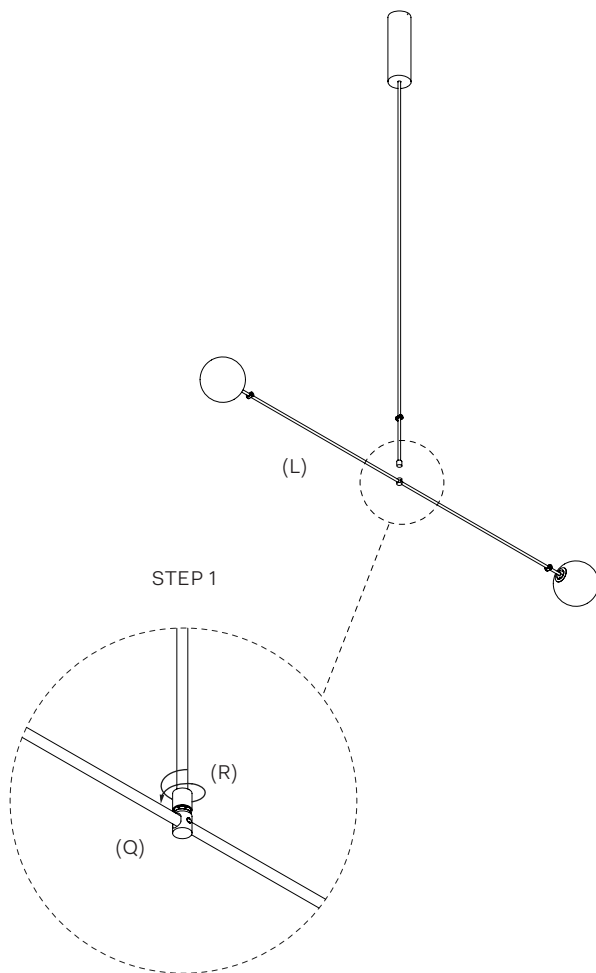

Fig. 17

Take the Tension Wire (A1) and wrap it around the Lamp Body 1 (L) and the Pendant Rod (P). Wrap the cable around the Horizontal Suspension Blocks (B1). While holding the Horizontal Body (L) in a horizontal position, loop the Tension Wire (A1) around both sides of the Pendant Rod Block (C1) located on the Pendant Rod (P) and adjust with the allen key. Adjust until the Pendant Rod Block (C1) on the Lamp Body 1 (L) is straight. Cut the extra cable as required to meet the Cable Block (D1). The Cable Block is supplied in the correct position, however if needed it can be adjusted to allow a different cable length.

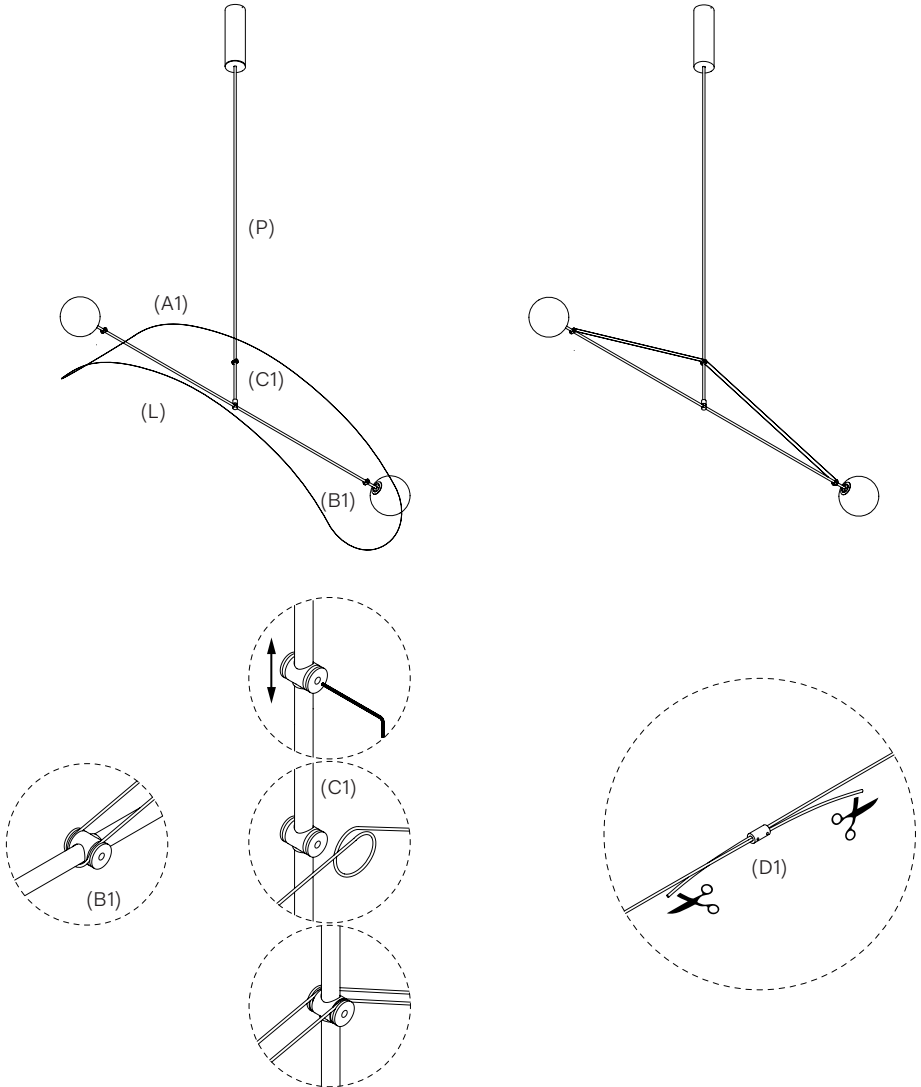
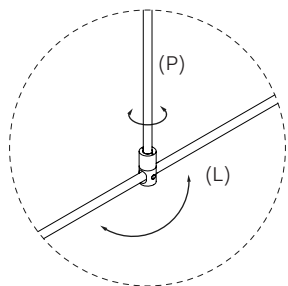
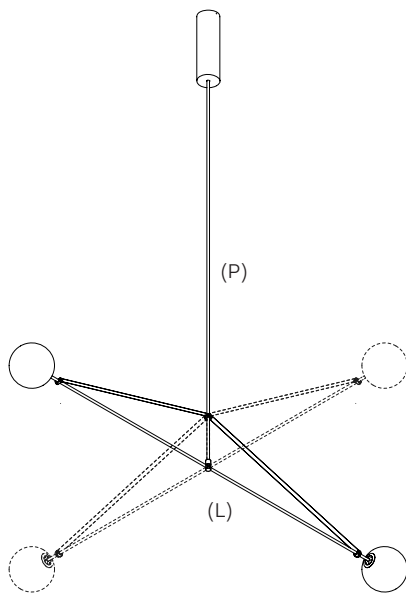

Fig. 18

Each joint has a free 360 rotation, allowing the Mobile Chandelier to be positioned according to the space. Lamp Body 1 (L) can rotate freely about the Pendant Rod (P).



Michael Anastassiades' design philosophy is to preserve the inherent qualities of given materials. All of our products are handmade and come in natural finishes, exposed to the elements without any protective lacquers. We look at oxidisation as part of a process that adds to the patina of an object, increasing beauty with time. We try our best for all goods to leave our premises in pristine condition, but sometimes products may arrive with minor oxidisation marks.

Whilst every effort is made to ensure an accurate representation of product colours, finishes and dimensions, Michael Anastassiades Ltd reserves the right to alter these details without notice, in compliance with its own production needs, technological changes or in response to the current market needs. Colour swatches are for reference only; Michael Anastassiades Ltd cannot guarantee exact colour match for any product finishes.

All designs are protected under copyright law. Michael Anastassiades holds the exclusive manufacturing and distribution rights worldwide. Copying will be prosecuted.

All light fixtures in this catalogue have CE marking compliance.

Michael Anastassiades Ltd.  
50 Rochester Place, London NW1 9JX  
T +44 (0)20 7928 7527  
sales@michaelanastassiades.com  
www.michaelanastassiades.com  
© 2023 Michael Anastassiades Ltd. All rights reserved.