

MICHAELANASTASSIADES

INSTALLATION INSTRUCTIONS



BALL LIGHT
CEILING MOUNTED, 2009

PRODUCT SPECIFICATIONS

SMALL BALL LIGHT

Bulb specifications 120V / 240V
G9 maximum wattage 5W
ø45mm white globe

Product weight: ~1kg

LARGE BALL LIGHT

Bulb specifications 120V / 240V
G9 maximum wattage 20W
ø95mm white globe

Product weight: ~2kg

120V / 240V dimmable LED triac

120V version supplied with paintable junction box cover.

BEFORE INSTALLING

Please keep these instructions for future reference. Please read instructions in full prior to installation noting all illustrations. Instructions should be followed precisely. If in any doubt about electrical safety, contact a qualified electrician.

Installation should always be carried out by a qualified electrician or a competent person in accordance with your current electrical regulation.

The electricity supply should always be isolated at its source (fuse box) before attempting any installation or maintenance. Please do not fit bulbs exceeding the maximum allowable wattage.

Ensure the circuit, to which the fixture is to be connected, has been installed and fused in accordance with your local electrical standards.

If the external flexible cable or cord is damaged, it should be replaced exclusively by MICHAEL ANASTASSIADES or a similar qualified person to avoid a hazard.

Please see the latest IEE Wiring Regulations for full details.

If a bulb requires replacement, always switch off the mains power and allow the fixture to cool.

Position the fixture where desired, ensuring that the area is suitable to support the weight of the fixture.

Determine the fixing method appropriate to the surface material.

Modifying any part of the fixture will void the products warranty.

MICHAEL ANASTASSIADES takes no responsibility for incorrectly installed lights & recommends that all fixtures should be installed by a qualified electrician.

CLEANING INSTRUCTIONS

Before cleaning, lighting fixtures must be turned off and unplugged from mains electricity. Whilst cleaning please be extremely careful and use the gloves provided.

Satin brass: Use the Scotch Brite pad (supplied in the product box) and gently rub the pad in the direction of the grain. Repeat until the natural patina is removed. On rubbing the Scotch Brite to the brass, grains will occur. The colour of the product will temporarily get lighter until it re-oxidises.

Plated Finish: Use a lightly damp soft dust cloth and gently go over marks until clean. Dry it afterwards with a soft dust cloth.

Patinated Finish: Use a dry soft dust cloth and gently go over marks until clean. The brass patina is achieved through an artisanal technique of applying pigments by hand during a hot patination process. Through this alchemic process, the brass is transformed whilst retaining the material's inherent qualities. It will mature and change overtime. The manner and speed in which it will change will depend on the environment, handling and the level and frequency of maintenance. Verdigris can also appear when the copper in the brass begins to oxidise.

Glass tube: Remove the bulb from the product. Using a lightly damp cloth, clean only the outside of the tube and dry it with a dry soft dust cloth. Only put the glass bulb back on the product once it is fully dry.

INSTALLATION PREPARATION

Whilst installing the fixture, please take care and use the gloves provided.

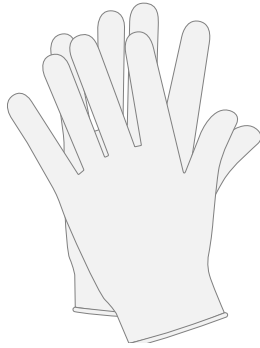

Turn off the electrical supply at the fuse box.

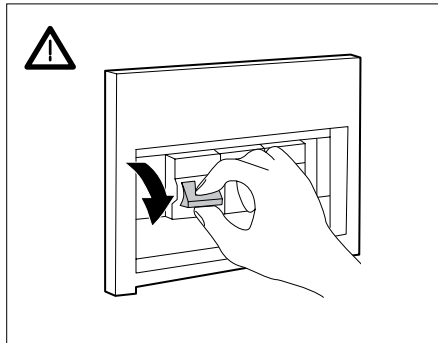

Use the guide below to ensure you follow the instructions that are relevant to your fixture.

Ball Light Ceiling Mounted, 240V	Fig.1	Fig.2	Fig.5	Fig.6	Fig.7	
Ball Light Ceiling Mounted, 120V	Fig.1	Fig.3	Fig.4	Fig.5	Fig.6	Fig.7

Parts Supplied

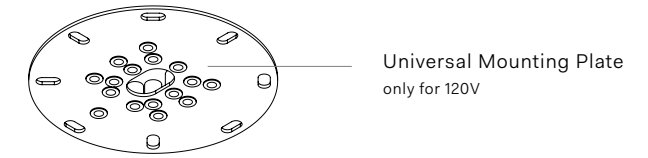

Universal Mounting Plate
only for 120V

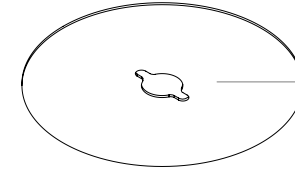

J-box cover
only for 120V

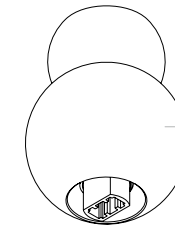

Lamp Body

*for the purpose of these instructions only the Small Ball Light is shown. Both Small and Large Ball light require the same installation method.

Additional Items Provided

Pair of Gloves
Allen key - 2mm

Fig. 1

Using the allen key provided unscrew the pin (C) located near the bulb holder. Separate the lamp body (A) from the backplate (B).

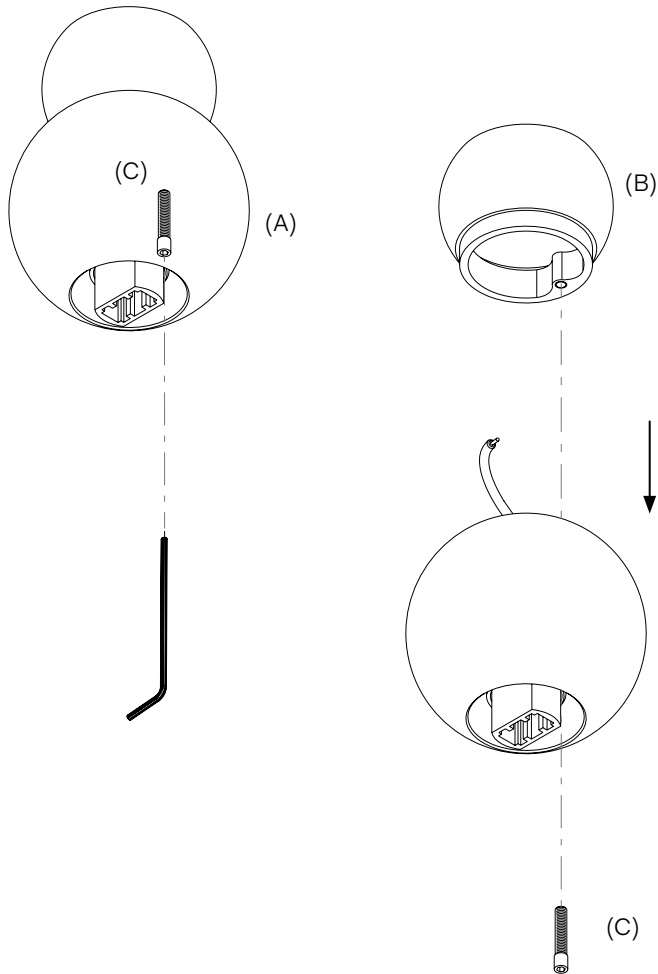

Fig. 2 For 240V Fittings

Place the backplate (B) onto the ceiling, centre it to the mains electrical supply cable and mark two holes to be drilled. Once drilled, insert wall anchors into the holes, ensuring that the area is able to support the entire weight of the fixture (noted on product specification). Screw the back plate onto the ceiling, making sure it is levelled.

Wall anchors and mounting screws are not supplied for this fixture. Determine the fixing method appropriate to the surface material before starting the project. Use fixings that are suited to the surface material and are sufficient to bear the weight of the light.

Go to Fig. 5 for next step.

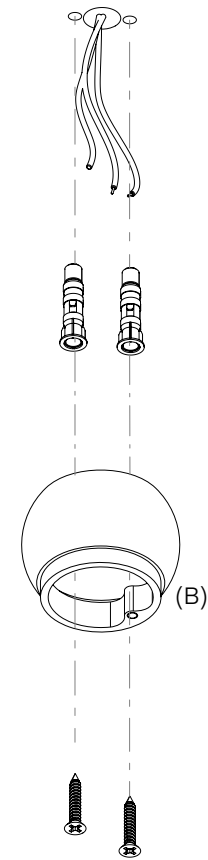
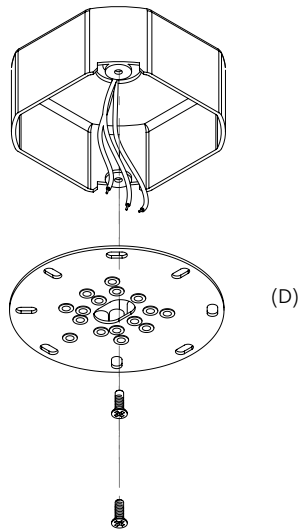

Fig. 3 For 120V Fittings

Screw the Universal Mounting Plate (D) onto the junction box, making sure it is levelled. Pull live, neutral and ground cables out through the central hole. Mounting screws are not supplied with this fixture as J-boxes can vary.



Note: Make sure the supplied Universal Mounting Plate is fastened directly to the junction box. The surface of the junction box should be set back 1/8" or 3mm from the mounting surface. This will ensure the best possible fit for ease of installation and final finish. Note below the correct and incorrect fit for optimum installation.

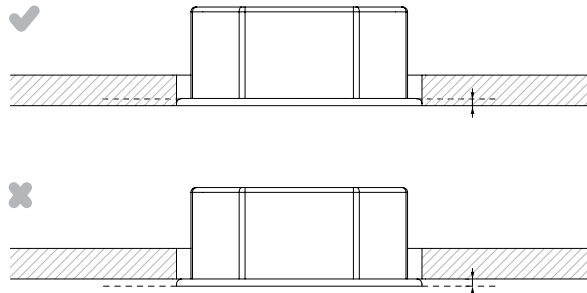
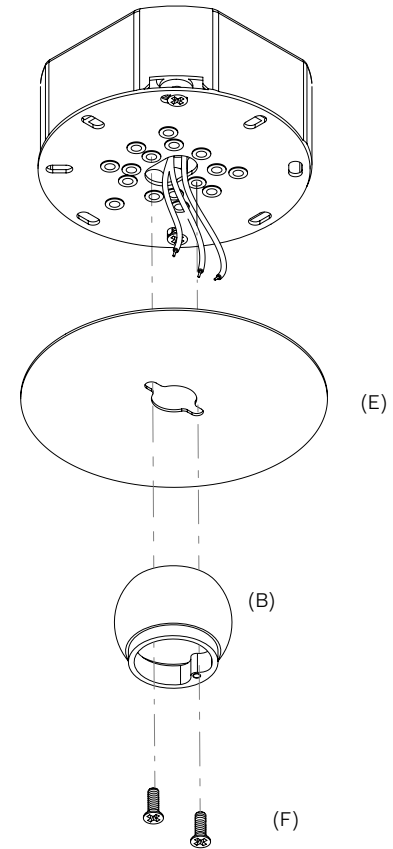

Fig. 4 For 120V Fittings

Feed the electrical cables through the central hole of the Junction box cover (E) and the backplate (B). Use screws supplied (F) to secure the light to the J-Box.



Paint over the J-box cover to match the ceiling finish.

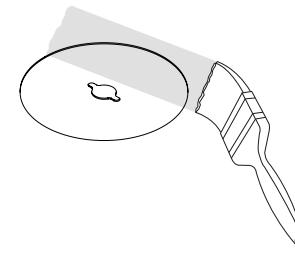

Fig. 5

Connect the live, neutral and earth of the mains electrical cable to the corresponding fixture wires using the connectors (G). Make sure all electrical cables match correctly.

See Cable Connection Guide for further reference.

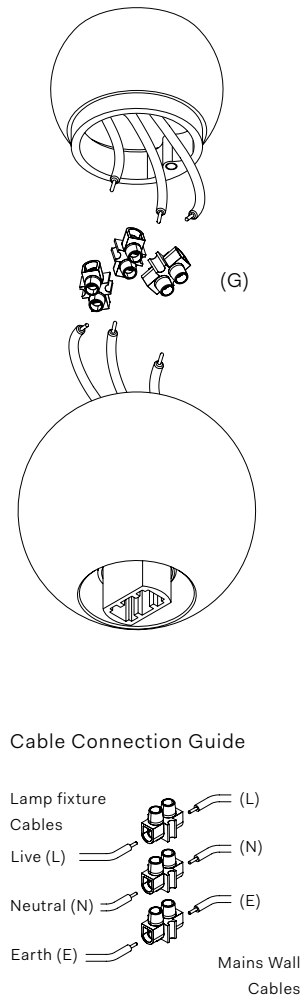

Fig. 6

Insert the main body (A) in the backplate (B) making sure to align the pin (C).

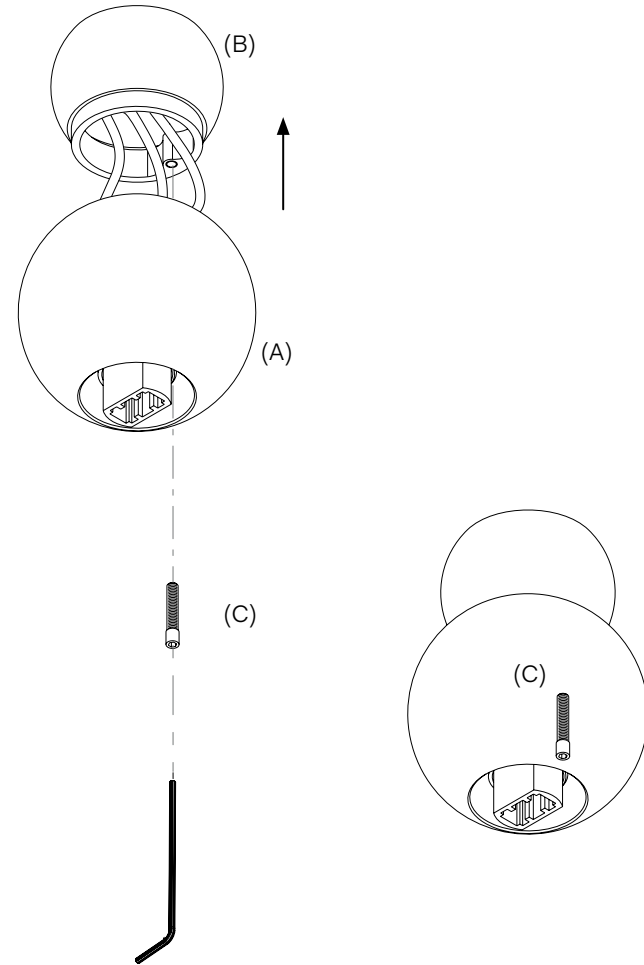
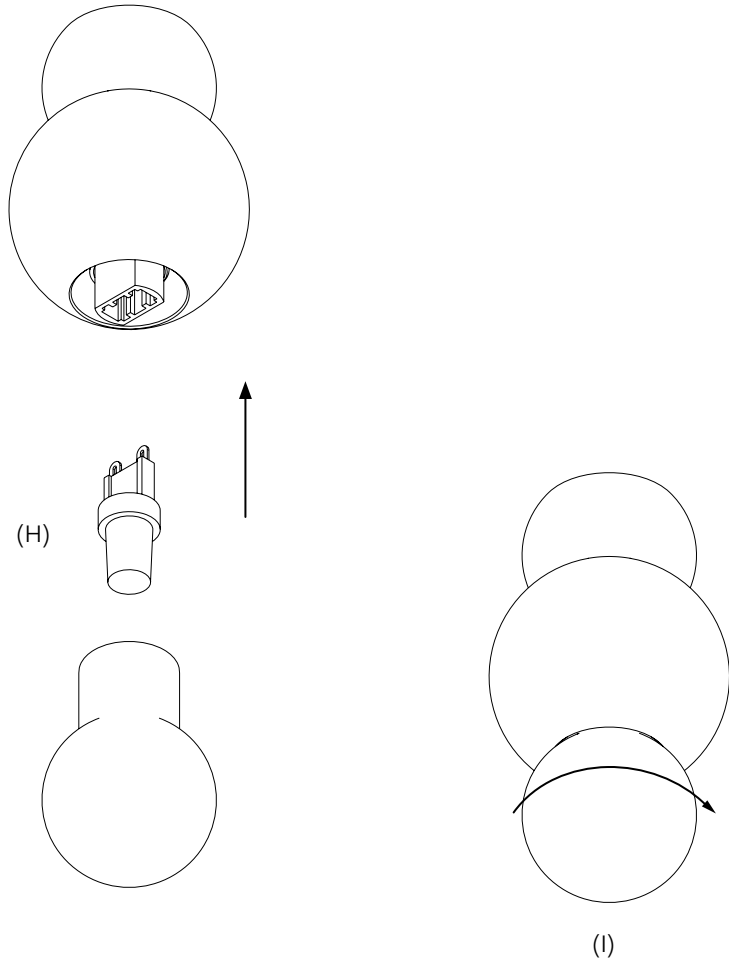

Fig. 7

Insert the G9 bulb (H) into the lamp holder and screw in the glass diffuser (I).



Michael Anastassiades' design philosophy is to preserve the inherent qualities of given materials. All of our products are handmade and come in natural finishes, exposed to the elements without any protective lacquers. We look at oxidisation as part of a process that adds to the patina of an object, increasing beauty with time. We try our best for all goods to leave our premises in pristine condition, but sometimes products may arrive with minor oxidisation marks.

Whilst every effort is made to ensure an accurate representation of product colours, finishes and dimensions, Michael Anastassiades Ltd reserves the right to alter these details without notice, in compliance with its own production needs, technological changes or in response to the current market needs. Colour swatches are for reference only; Michael Anastassiades Ltd cannot guarantee exact colour match for any product finishes.

All designs are protected under copyright law. Michael Anastassiades holds the exclusive manufacturing and distribution rights worldwide. Copying will be prosecuted.

All light fixtures in this catalogue have CE marking compliance.

Michael Anastassiades Ltd.
50 Rochester Place, London NW1 9JX
T +44 (0)20 7928 7527
sales@michaelanastassiades.com
www.michaelanastassiades.com
© 2024 Michael Anastassiades Ltd. All rights reserved.