

up to
3000
(10')
standard

up to
24600
(80')
custom

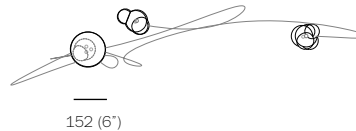

- PENDANTS: three
- MOUNTING: white canopy 152mm (6") in diameter x 32mm (1.3") deep
- LAMPING: 1.5w LED (4.5w total)
- CABLE: adjustable lengths. 3000mm (10') standard / up to 30500mm (100') maximum
- MATERIALS: blown and dipped glass, cast borosilicate glass cap, white hardware and swag hooks, braided metal coaxial cable, aircraft cable, electrical components.
- WEIGHT: approximately 5kg (11lb)
- POWER SUPPLIES: integral (remote mount recommended)

DESCRIPTION

57.3 is a cluster configuration of three 57 pendants suspended from a round canopy. This fixture is designed to be horizontal, meaning that the pendants don't hang directly below, but instead trail off across a space, around a corner or simply deviate from their gravitational directive. As such, this fixture is designed to be hung from any number of optional swag points.

57 is an exploration of a technique used for producing closed cell foam. The process involves trapping voids of air of different sizes and configurations within a glass matrix, yielding a shape loosely referencing a rain cloud. These pockets of air remain invisible when the piece is off, but come alive to reveal an interior universe when the piece is illuminated. By virtue of the fabrication process, each piece is completely unique.

NOTES

+ Purchase replacement lamps online at www.bocci.com/shop/bulbs

US Patent # D796 732
EU Patent # 002268581-0001 to 0006

Made in Vancouver, Canada

Vancouver
sales@bocci.com
www.bocci.com

Berlin
europe@bocci.com
www.bocci.com

approx 5kg (11lb)

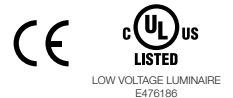

CLUSTER

57.3

Design by Omer Arbel
PRODUCT SPECIFICATION

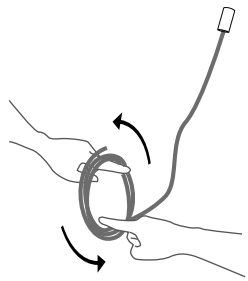

1

Very carefully uncoil the braided coaxial cable in a spool like manner. Insert your index fingers into opposite sides of the roll then rotate your fingers around each other to unroll the coaxial cable.

Use patience: allow the cable to uncoil completely to avoid kinks.

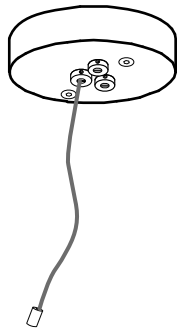

2

Determine the overall drop for the pendant fixture.

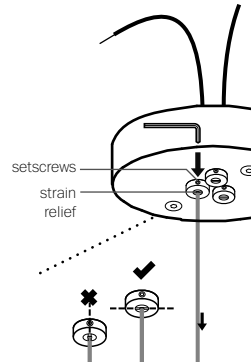

3

Thread the coaxial cables through the canopy, use a 2mm Allen key to loosen the setscrew in the canopy and gently feed the cable through until you have reached your desired drop length.

Use Allen key to tighten the setscrew to hold the strain relief and secure the coaxial cable at its new length. Perform a gentle tug test to ensure it is secure.

DO NOT OVERTIGHTEN.

Note: The strain relief is a black plastic collar around the coaxial cable. There is a single slot opening on the side of the strain relief component. It is essential that this opening is oriented at 90 degrees to set screw chamber. There can be no contact between the set screw and the cable.

RISK OF ELECTRIC SHORT!

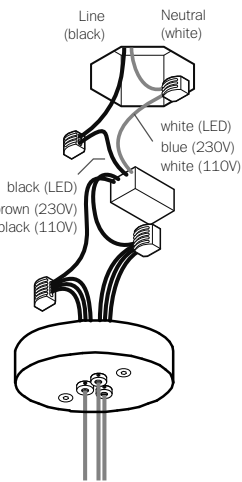

4

LED: connect the black wire to black and white wire to white wire.

Connect the coaxial cable to the open slots in the terminal block on the 12V side of the power supplies.

Ensure that the braided outer wires are all connected to one 12V output wire and all inner insulated wires are connected to the other or a short will occur.

Once all coaxial connections are made, lift the fixture into position and connect the line voltage to the open slot in the appropriate terminal block.

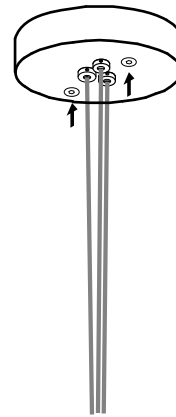

5

The client is responsible to ensure fasteners are attached to a robust structural substrate.

Tuck the power supply and wiring into the canopy. Line up the fastener holes or connect directly to structural ceiling surface using the fasteners provided.

Turn power to fixture on.

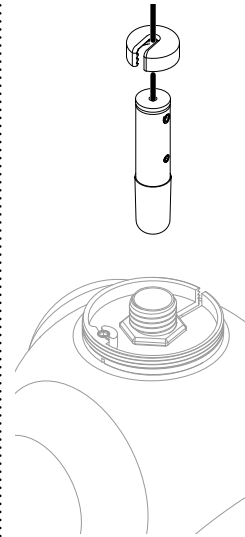

6

Attach lamp to the coax socket. Slide the brass cap onto the coaxial cable.

Ensure power to lamp is working correctly.

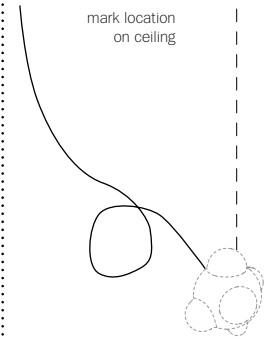

7

Mark the location for the swag hook screw on the ceiling.

CLUSTER

57.3

Design by Omer Arbel
PRODUCT INSTALLATION INSTRUCTIONS

© 2021, Bocci Design and Manufacturing Inc. All rights reserved. Any inquiries should be directed to: info@bocci.com

BOCCI

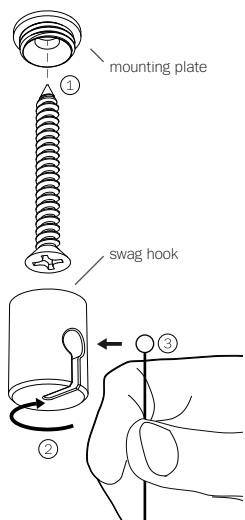

8

Ensure that the ceiling at the swag location is strong enough to hold 2kg (5lbs) before attaching swag hook with the provided screws.

Thread the swag hook on to the mounting plate, ensuring all the threads are engaged.

Slide the ball end of the aircraft into the slot on the swag hook.

Note: Some installations call for the use of a swag jack ring, which allows pendants to be swagged from the canopy.

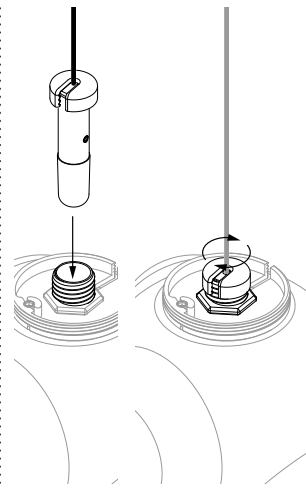

9

Insert the lamp assembly into the glass pendant.

Thread the brass cap onto the pendant.

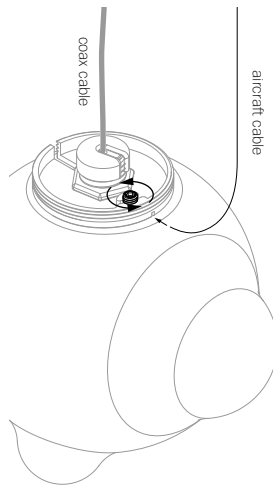

10

Loosen setscrew and thread the aircraft cable through the slot.

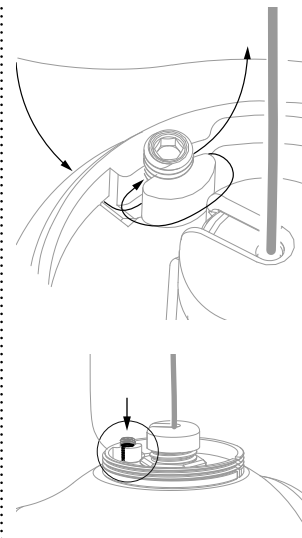

11

Feed the aircraft cable under the setscrew and make a loop.

Adjust the height and tighten the setscrew to secure the aircraft cable.

Cut the aircraft cable using wire cutters.

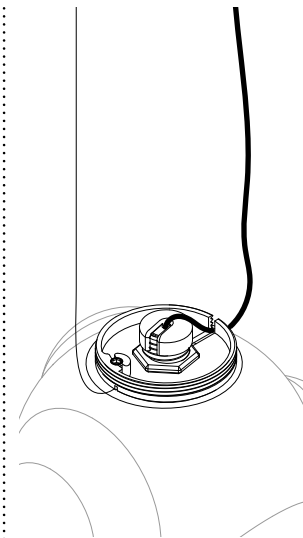

12

Slide the coax cable through the slot on the pendant holder.

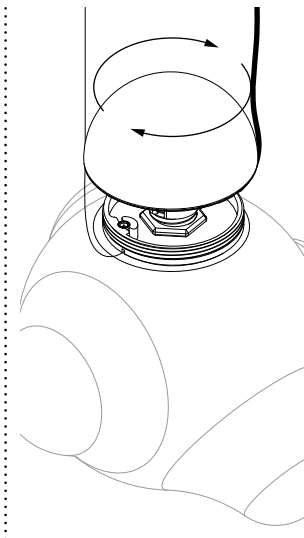

13

Thread glass cap onto the pendant, ensuring that the coax remains seated in the slot.

Clean fingerprints from surfaces.

For additional assistance, please contact Bocci:

Vancouver
sales@bocci.com
www.bocci.com

Berlin
europe@bocci.com
www.bocci.com

US Patent # D796 732
EU Patent # 002268581-0001
to 0006

Made in Vancouver, Canada



LOW VOLTAGE LUMINAIRE
E476186

CLUSTER

57.3

Design by Omer Arbel
PRODUCT INSTALLATION INSTRUCTIONS

© 2022, Bocci Design and Manufacturing Inc. All rights reserved. Any inquiries should be directed to: info@bocci.com

BOCCI